

W10IW8M-RTD1ML

10.1" Intel® Core™ i5-8265U Defence Ultra Rugged Tablet



KEY FEATURES

- 10.1" 1920 x 1080 LED Panel with direct optical bonding, Defence Ultra Rugged Tablet PC
- 8th Gen. Intel® Core™ i5-8265U, 1.6 GHz (turbo up to 3.90 GHz)
- Adjustable Kickstand that is Convertible to a handle
- Ecological seals protect ports as well as connectors from moisture and dust
- MIL-STD-38999 connector for Giga LAN, RS232/RS422 and Power Input
- With daylight-readable screen 800 nits optical bonding for clarity increasing and readability enhancing



SPECIFICATIONS

Display			
Touch / Glass	Projected Capacitive Multi Touch Screen	Resolution	1920x1080
Size	10.1 inches	Contrast Ratio	800:1
Panel Brightness	800 nits	View Angles	85,85,85,85
System Specification			
Processor	Intel Core i5-8265U 1.6GHz (up to 3.9GHz)	Memory	4GB SODIMM DDR4-2400 8GB SODIMM DDR4-2400 (Optional) 16GB SODIMM DDR4-2400 (Optional)
Storage	1 x 128GB M.2 SSD 256GB M.2 SSD (Optional) 512GB M.2 SSD (Optional)	Security	TPM 2.0
Operating System	Windows 10 IoT Enterprise (64 bit) Linux Ubuntu 20.04 (Optional)	WLAN	802.11 a/b/g/n/ac
BT	Support	WWAN	4G/ LTE or 3G (Optional)
GNSS	Supports GPS GLONASS, Galileo, BeiDou (Optional)		
Mechanical			
Dimension	266 x 222 x 50.5 mm	Weight	2.4 kg
Enclosure	Magnesium Alloy Housing with All-Around Elastomeric Rubber	Cooling System	Fanless design
Docking Housing	nan		
Power			
Battery	11.1V, 5200mAh Lithium-Ion Battery (6cells)	Battery Operating Time	8 Hours
Power Rating	9-36V DC in (MIL-DTL-38999/1 connector)	Adapter	100-240V, 50-60Hz / 19V DC
Environment			
Operating Humidity	10% to 90% RH, non-condensing	Operating Temperature	-20°C to 60°C (AC mode), -10°C to 50°C (Battery mode)
Storage Temperature	-30°C to 70°C (-22°F to 158°F)	Shock	MIL-STD-810G Method 516.6 Procedure I
Vibration	MIL-STD-810G Method 514.6 Procedure I	IP rating	IP54

Drop	MIL-STD-810G Method 516.6, 4 ft		
Certification			
Certification	CE, FCC		
Control			
Button	1 x Power, 1 x Menu, 2 x Function Key, 2 x Brightness Control Key		
Accessory			
Accessory	Cordon d'alimentation et adaptateur Batterie standard Guide de démarrage rapide Manuel papier + CD Stylet Câble alimentation + Ethernet MILSTD38999 Câble RS232/RS422/RS852 MILSTD38999	Optional Accessory	Station d'accueil multifonctions Kit d'adaptation pour véhicule Chargeur voiture Lanière pour main Lanière épaule Sacoche
IO Ports			
USB Port	2 x USB 3.0	Serial Port	1 x RS232/RS422 /485 + 1 x RS422 Port(MIL-STD-38999 connector)
Video	1 x HDMI	Audio	2 x 1 Watt Speaker
LAN	2 x RJ45-10/100/1000 Mbps LAN(MIL-STD-38999 connector)	Indicator	4x LED Indicator for Power, Battery, SSD, RF status

DIMENSIONS UNIT:MM

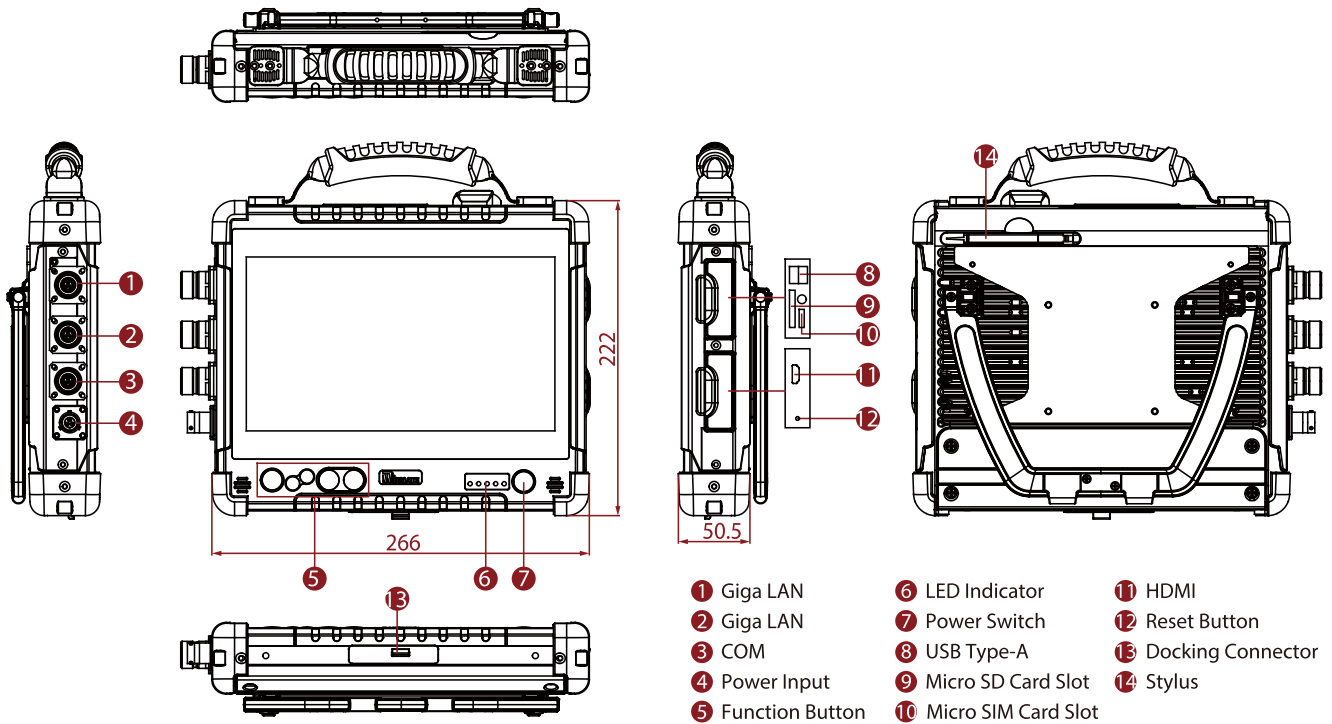

NOTE

1. Measured at dimming LCD brightness. Varies depending on the usage conditions, or when an external device is attached.
2. This is a simplified drawing and some components are not marked in detail.
3. Default uses the silver defence connector with RoHs, optional green defence connector without RoHs.

Tento produkt můžete zakoupit u společnosti AutoCont IPC a.s.



AutoCont IPC a.s.

Váš dodavatel průmyslových počítačů, komponent a speciálních průmyslových IT systémů.

 Uhlířská 1064/3, 710 00 Ostrava, Česká republika

 obchod@autocont-ipc.cz

 +420 552 301 002

 www.autocont-ipc.cz



PRŮMYSLOVÉ POČÍTAČE

fanless embedded PC, do racku, ...



POČÍTAČE S DISPLEJEM

panelové PC, terminály, do vozidel, ...



AUTOMATIZACE A SBĚR DAT

převodníky, karty, moduly, switche, ...



PERIFERIE A KOMPONENTY

monitory, klávesnice, desky, skříně, ...



NOTEBOOKY A TABLETY

odolné, windows, android, IP65, ...



INFORMAČNÍ KIOSKY

interiérové, venkovní, ...



MEDICÍNSKÁ TECHNIKA

počítače, tablety, LCD, klávesnice, ...



SOFTWAREVÁ ŘEŠENÍ

pro výrobu, zaměstnance, kiosky, ...



PŘEJÍT DO E-SHOPU

eshop.autocont-ipc.cz



DOPRAVA ZDARMA

Doprava zdarma v ČR a SR při objednávce nad 10 000 Kč bez DPH nebo nad 400 EUR.



PRODLOUŽENÁ ZÁRUKA

Záruka 2 roky na vyráběné počítače s možností jejího prodloužení až na 5 let.



ODMĚNA ZA VĚRNOST

Pravidelní zákazníci u nás nakupují za nižší ceny. Výše slevy se odvíjí od realizovaného obrátu.



SERVIS ON-SITE A IN-TIME

K projektovým dodávkám nabízíme rozšířenou podporu a servis s garancí výměny zařízení do 48 hodin.