

W10FA3S-GSH2

10.1" NXP i.MX6 G-WIN GS-Series Full IP65 PCAP Panel PC



KEY FEATURES

- 10.1" 1280 x 800 PCAP touchscreen
- NXP i.MX6 Dual Core 1GHz
- Fanless cooling system
- Ultra-low power consumption
- Full IP65



SPECIFICATIONS

System Specification			
Processor	NXP i.MX6 Dual Core, 1.0GHz	Memory	1GB 2GB (Optional)
Storage	Onboard 16GB eMMC Onboard 32GB eMMC (Optional)	Operating System	Linux Ubuntu 18.04 (Optional) Android 6.0 (Optional) Debian 7.0 (Optional) Linux 4.1.15 QT 5.5 (Optional)
Display			
Resolution	1280x800	Size	10.1 inches
Contrast Ratio	800:1	Panel Brightness	350 nits 1000 nits(Optional)
View Angles	85,85,85,85	Active Area	216.96 x135.6 mm
Touch / Glass	Projected Capacitive Multi Touch Screen Protection Glass (Optional)		
Environment			
Operating Humidity	10% to 95% RH	Operating Temperature	-15 °C to 55 °C
Storage Temperature	-30°C to 60°C	Shock	40g for 11ms
Vibration	1.48/1.90/2.24 g rms for XYZ/ 5-500Hz	IP rating	Full IP65
Certification			
Certification	Compliant with MIL-STD-810F/G for vibration / shock, CE, FCC		
IO Ports			
USB Port	1 X USB 2.0 (M12 type)	Serial Port	1 x RS232 (M12 type)(Optional 422/485)
SD Card Slot	1 x Micro SD Card Slot	Audio	1 x Speaker
LAN	1 x LAN-10/100/1000 (M12 type)		
Mechanical			
Dimension	263.28 x 172 x 40.2 mm	Mounting	VESA Mount/ Panel Mount
Enclosure	Aluminum	Cooling System	Fanless Design
Power			
Power Rating	12V DC (M12 type)		

Accessory

Accessory	Quick Start Guide (Hardcopy) Driver CD & User Manual M12 Power Cable M12 Serial Interface Cable M12 USB/ LAN Cable I/O Protective Cap x 3
------------------	--

DIMENSIONS UNIT:MM

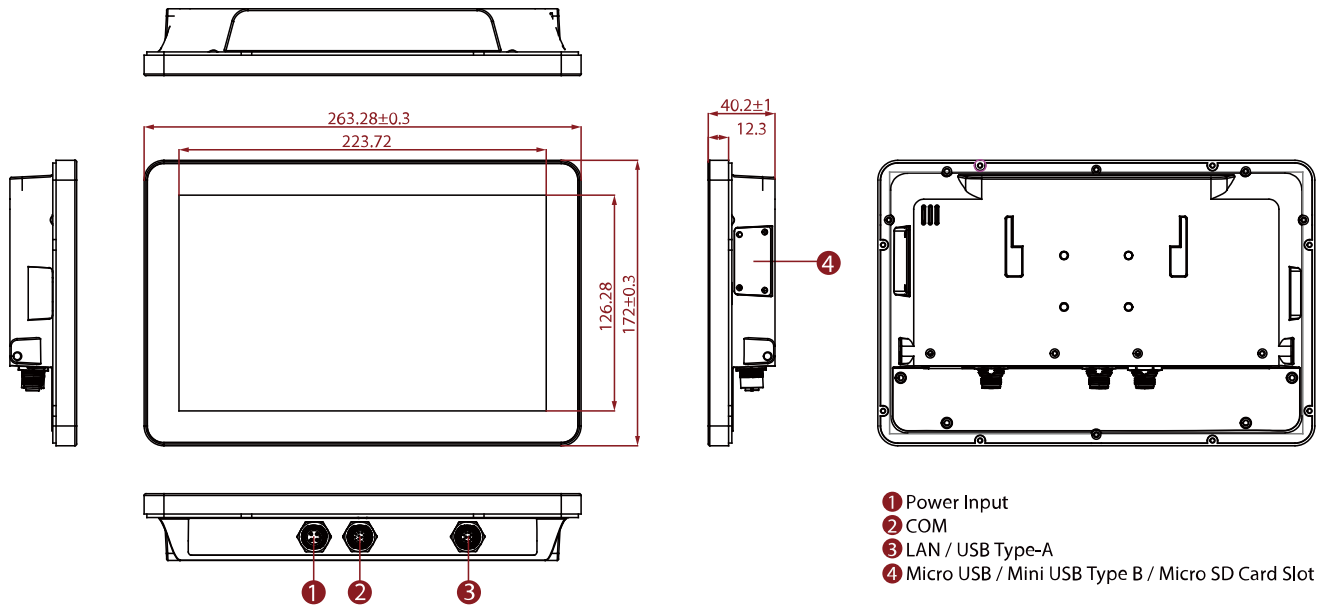

NOTE

1. This is a simplified drawing and some components are not marked in detail.
2. Please contact our sales representative if you need further product information.
3. All specifications are subject to change without prior notice.
4. The product shown in this datasheet is a standard model. For diagrams that contain customized or optional I/O, please contact the Winmate Sales Team for more information.

Tento produkt můžete zakoupit u společnosti AutoCont IPC a.s.



AutoCont IPC a.s.

Váš dodavatel průmyslových počítačů, komponent a speciálních průmyslových IT systémů.

 Uhlířská 1064/3, 710 00 Ostrava, Česká republika

 obchod@autocont-ipc.cz

 +420 552 301 002

 www.autocont-ipc.cz



PRŮMYSLOVÉ POČÍTAČE

fanless embedded PC, do racku, ...



POČÍTAČE S DISPLEJEM

panelové PC, terminály, do vozidel, ...



AUTOMATIZACE A SBĚR DAT

převodníky, karty, moduly, switche, ...



PERIFERIE A KOMPONENTY

monitory, klávesnice, desky, skříně, ...



NOTEBOOKY A TABLETY

odolné, windows, android, IP65, ...



INFORMAČNÍ KIOSKY

interiérové, venkovní, ...



MEDICÍNSKÁ TECHNIKA

počítače, tablety, LCD, klávesnice, ...



SOFTWAREVÁ ŘEŠENÍ

pro výrobu, zaměstnance, kiosky, ...



PŘEJÍT DO E-SHOPU

eshop.autocont-ipc.cz



DOPRAVA ZDARMA

Doprava zdarma v ČR a SR při objednávce nad 10 000 Kč bez DPH nebo nad 400 EUR.



PRODLOUŽENÁ ZÁRUKA

Záruka 2 roky na vyráběné počítače s možností jejího prodloužení až na 5 let.



ODMĚNA ZA VĚRNOST

Pravidelní zákazníci u nás nakupují za nižší ceny. Výše slevy se odvíjí od realizovaného obrátu.



SERVIS ON-SITE A IN-TIME

K projektovým dodávkám nabízíme rozšířenou podporu a servis s garancí výměny zařízení do 48 hodin.