

R19IT3S-67FTP(HB)

19" Intel® Core™ i5-1135G7 G-WIN Full IP67 Series Panel PC



KEY FEATURES

- Totally sealed Full IP67 Design
- High performance / low power 11th Generation (Tiger Lake) Intel® Core™ i5-1135G7 2.4GHz (turbo to 4.2GHz)
- 19-inch sunlight viewable 400 nits LCD panel (Optional for 1000 nits High Brightness)
- -10 to 55°C wide operating temperature
- Fanless, streamlined enclosure for highly efficient heat dissipation
- Touch screen control button to enable/disable touch screen interface
- Rugged Front Anti-Impact Design
- Front control membrane keys Lockable by software
- Optical Bonding with Panel & Touch Screen to increase the clarity and transparency



SPECIFICATIONS

System Specification			
WLAN	Support (Optional)	BT	Support (Optional)
Processor	Intel Core i5-1135G7 2.4GHz (up to 4.2GHz)	Memory	1 x SO-DIMM, DDR4 3200 MHz, 4GB 8GB (Optional) 16GB (Optional) 32GB (Optional)
Storage	1 x M.2 2280 M-Key NVMe SSD 128GB 256GB (Optional) 512GB (Optional) 1TB (Optional) 2TB (Optional) 4TB (Optional)	Ethernet controller	1 x Intel® Ethernet Controller
Security	TPM 2.0	Operating System	Windows 11 IoT Enterprise (64 bit) (Optional) Windows 11 Pro 64 bit (Optional) Windows 10 IoT Enterprise (64 bit) (Optional) Linux Ubuntu 22.04 (Optional)
Display			
Resolution	1280x1024	Size	19.0 inches
Contrast Ratio	1000:1	Panel Brightness	400 nits 1000 nits(Optional)
View Angles	85,85,80,80	Active Area	376.32x301.06 mm
Touch / Glass	Projected Capacitive Multi Touch Screen Bonding With Panel	Optional function	High brightness Panel for sunlight readable (Optional)
Mechanical			
Dimension	474 x 410 x 111 mm	Weight	9.8 kg
Mounting	Panel mount VESA Mount	Enclosure	Aluminum Housing
Cooling System	Fanless design	Cut out	462 x 386 mm
Environment			
Operating Humidity	10% to 90% RH, Non-Condensing	Operating Temperature	-10°C to 55°C -40°C to 70°C (with intelligent heater)
Storage Temperature	-30°C to 70°C	Shock	MIL-STD-810G Method 516.6 Procedure I

Vibration	MIL-STD-810G Method 514.6 Procedure I	IP rating	IP67
Certification			
Certification	CE, FCC		
IO Ports			
Power Input	1 x M12 waterproof connector for 9~36V DC	USB Port	1 x M12 waterproof connector for 2 x USB2.0 1 x Waterproof USB Type-A Connector with cover
Serial Port	1 x M12 waterproof connector for RS232	LAN	1 x waterproof Giga LAN RJ45 connector
Indicator	1 x LED Indicator for power 1 x LED Indicator for storage 1 x LED Indicator for heater 1 x LED Indicator for LAN 1 x LED Indicator for lock touch		
Control			
Button	1 x Power Button 1 x Brightness up Button 1 x Brightness down Button 1 x Button for locking touch function 1 x Programmable function key		
Accessory			
Accessory	External open wire Power cable with waterproof connector External USB cable with waterproof connector External COM cable with waterproof connector External LAN cable with waterproof connector Waterproof caps RJ45 female-female converter Mounting clips VESA screws	Optional Accessory	100~240V AC to DC 120W Adapter with power cord (Optional)

DIMENSIONS UNIT:MM

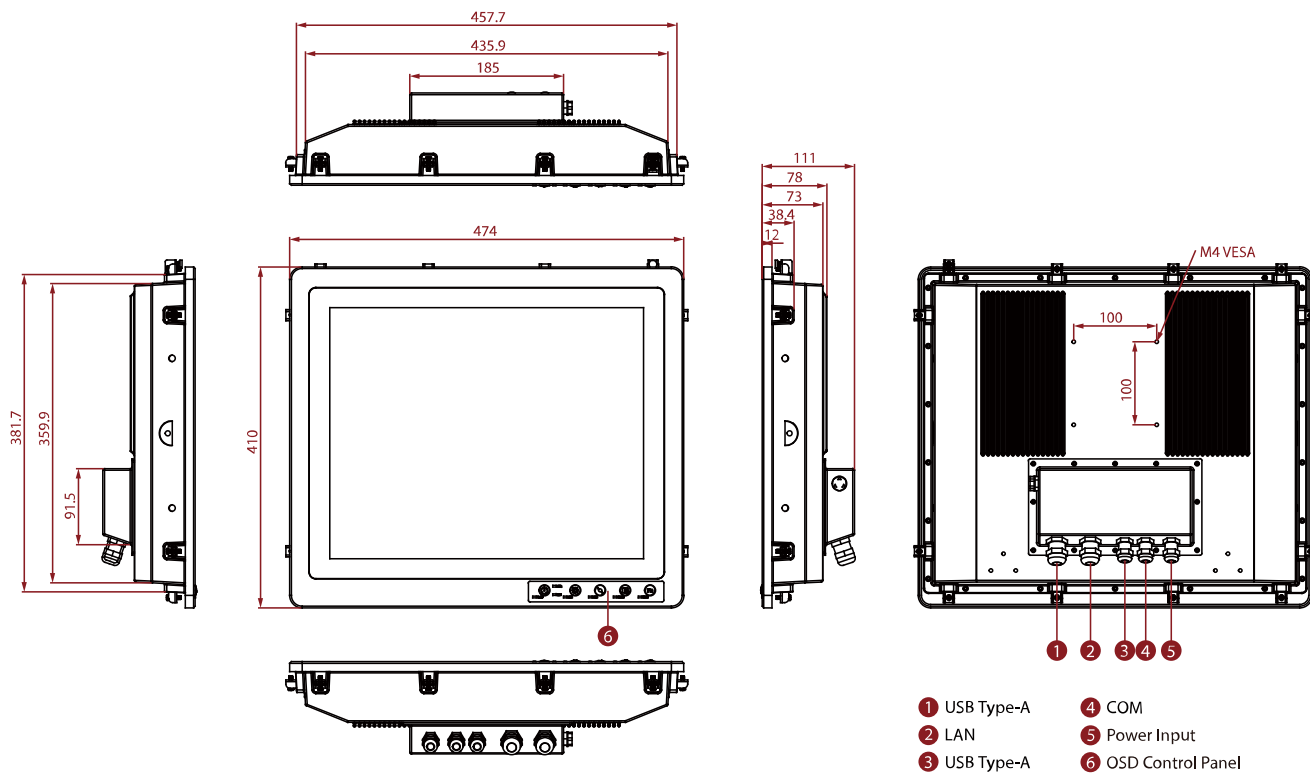

NOTE

1. This is a simplified drawing and some components are not marked in detail.
2. Please contact our sales representative if you need further product information.
3. All specifications are subject to change without prior notice.
4. The product shown in this datasheet is a standard model. For diagrams that contain customized or optional I/O, please contact the Winmate Sales Team for more information.

Tento produkt můžete zakoupit u společnosti AutoCont IPC a.s.



AutoCont IPC a.s.

Váš dodavatel průmyslových počítačů, komponent a speciálních průmyslových IT systémů.

 Uhlířská 1064/3, 710 00 Ostrava, Česká republika

 obchod@autocont-ipc.cz

 +420 552 301 002

 www.autocont-ipc.cz



PRŮMYSLOVÉ POČÍTAČE

fanless embedded PC, do racku, ...



POČÍTAČE S DISPLEJEM

panelové PC, terminály, do vozidel, ...



AUTOMATIZACE A SBĚR DAT

převodníky, karty, moduly, switche, ...



PERIFERIE A KOMPONENTY

monitory, klávesnice, desky, skříně, ...



NOTEBOOKY A TABLETY

odolné, windows, android, IP65, ...



INFORMAČNÍ KIOSKY

interiérové, venkovní, ...



MEDICÍNSKÁ TECHNIKA

počítače, tablety, LCD, klávesnice, ...



SOFTWAREVÁ ŘEŠENÍ

pro výrobu, zaměstnance, kiosky, ...



PŘEJÍT DO E-SHOPU

eshop.autocont-ipc.cz



DOPRAVA ZDARMA

Doprava zdarma v ČR a SR při objednávce nad 10 000 Kč bez DPH nebo nad 400 EUR.



PRODLOUŽENÁ ZÁRUKA

Záruka 2 roky na vyráběné počítače s možností jejího prodloužení až na 5 let.



ODMĚNA ZA VĚRNOST

Pravidelní zákazníci u nás nakupují za nižší ceny. Výše slevy se odvíjí od realizovaného obrátu.



SERVIS ON-SITE A IN-TIME

K projektovým dodávkám nabízíme rozšířenou podporu a servis s garancí výměny zařízení do 48 hodin.