

R15L100-VMC3(HB)

15" G-WIN VM Series Display



KEY FEATURES

- High Quality 15" XGA panel, 1024 x 768 resolution
- 5 Wire resistive touch screen
- -10 ~ +55°C Wide Range Operating Temperature
- Anti-Corrosion housing with Fanless Design
- Built-in ambient Light sensor
- Front IP65 Dust & Waterproof Protection (Except I/O ports)
- 10 ~ 60V DC Isolation Wide Range Power Input. Optional Ignition on/off control function.



SPECIFICATIONS

| Display | | | |
|----------------------------|--|------------------------------|--|
| Touch / Glass | Resistive Touch Screen (Optional) Protection Glass Without Touch Function (Optional) | Optional function | High brightness Panel for sunlight readable (Optional) |
| Resolution | 1024x768 | Size | 15.0 inches |
| Contrast Ratio | 2000:1 | Panel Brightness | 300 nits 1000 nits(Optional) |
| Display Color | 16.2M Colors | View Angles | 88,88,88,88 |
| Active Area | 304.1x228.1 mm | | |
| Mechanical | | | |
| Dimension | 398 x 308 x 58 mm | Weight | 4.2 kg |
| Mounting | VESA Mount Yoke Mount | Enclosure | Aluminum Housing |
| Cooling System | Fanless design | | |
| Environment | | | |
| Operating Humidity | 10% to 90% RH, Non-Condensing | Operating Temperature | -10°C to 55°C |
| Storage Temperature | -30°C to 70°C | Shock | MIL-STD-810G Method 516.6 Procedure I (Optional) |
| Vibration | MIL-STD-810G Method 514.6 Procedure I | IP rating | Front IP65 |
| Certification | | | |
| Certification | CE, FCC | | |
| IO Ports | | | |
| Power Input | 1 x 10~60V DC, 3-Pin Terminal Block | USB Port | 1x USB type-A for touch screen control (Optional) |
| Serial Port | 1 x RS232 D-sub9 for touch screen control (Optional) | Video | 1x VGA input 1x HDMI input (Optional) |
| Indicator | 1 x LED Indicator for power 1 x LED Indicator for status | | |
| Control | | | |
| Button | 1 x Power Button 1 x Adjust up button 1 x Adjust down button 1 x ESC (Auto) button 1 x Menu button | | |

Accessory

Accessory Open Wire Cable with terminal block connector
External VGA cable
VESA screws

Optional Accessory Yoke mount stand (Optional)
100~240V AC to DC 50W Adapter with power cord (Optional)
External USB/COM cable for touchscreen control (Optional)
External HDMI cable (Optional)

System Specification

DIMENSIONS UNIT:MM

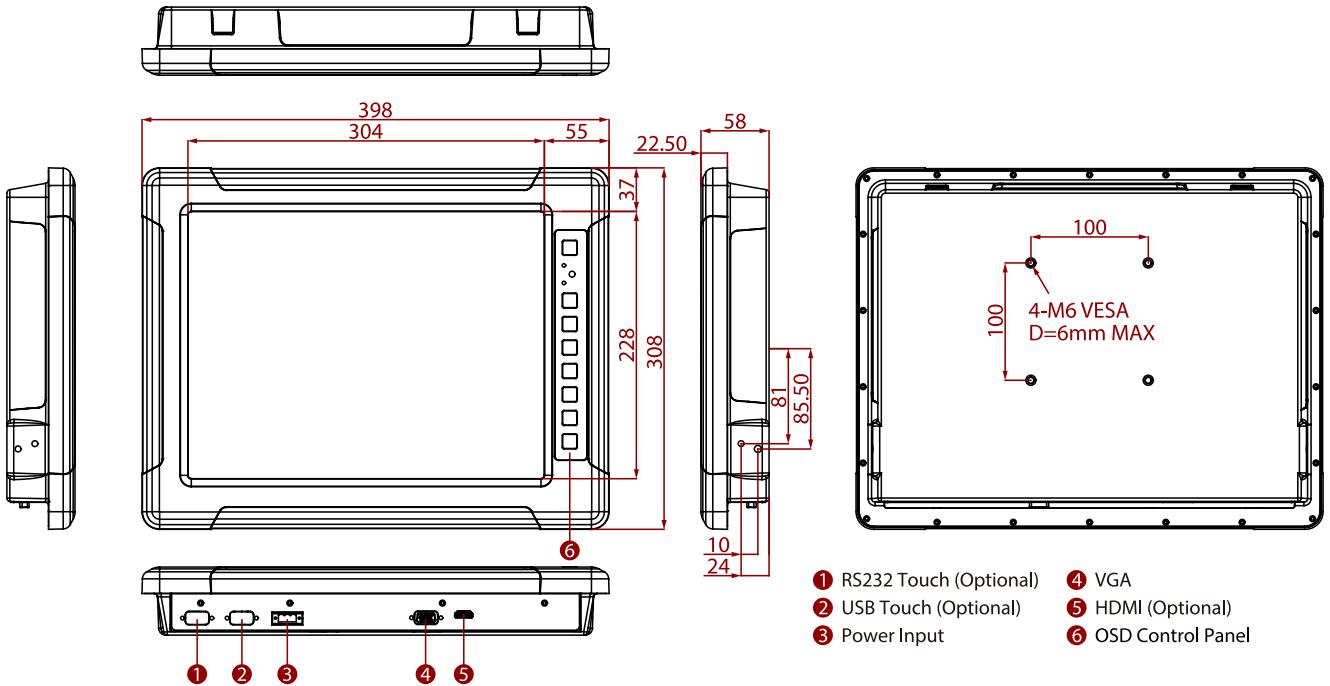

NOTE

1. This is a simplified drawing and some components are not marked in detail.
2. The product shown in this datasheet is a standard model. For diagrams that contain customized or optional I/O, please contact the Winmate Sales Team for more information.
3. All specifications are subject to change without prior notice.

Tento produkt můžete zakoupit u společnosti AutoCont IPC a.s.



AutoCont IPC a.s.

Váš dodavatel průmyslových počítačů, komponent a speciálních průmyslových IT systémů.

 Uhlířská 1064/3, 710 00 Ostrava, Česká republika

 obchod@autocont-ipc.cz

 +420 552 301 002

 www.autocont-ipc.cz



PRŮMYSLOVÉ POČÍTAČE

fanless embedded PC, do racku, ...



POČÍTAČE S DISPLEJEM

panelové PC, terminály, do vozidel, ...



AUTOMATIZACE A SBĚR DAT

převodníky, karty, moduly, switche, ...



PERIFERIE A KOMPONENTY

monitory, klávesnice, desky, skříně, ...



NOTEBOOKY A TABLETY

odolné, windows, android, IP65, ...



INFORMAČNÍ KIOSKY

interiérové, venkovní, ...



MEDICÍNSKÁ TECHNIKA

počítače, tablety, LCD, klávesnice, ...



SOFTWAREVÁ ŘEŠENÍ

pro výrobu, zaměstnance, kiosky, ...



PŘEJÍT DO E-SHOPU

eshop.autocont-ipc.cz



DOPRAVA ZDARMA

Doprava zdarma v ČR a SR při objednávce nad 10 000 Kč bez DPH nebo nad 400 EUR.



PRODLOUŽENÁ ZÁRUKA

Záruka 2 roky na vyráběné počítače s možností jejího prodloužení až na 5 let.



ODMĚNA ZA VĚRNOST

Pravidelní zákazníci u nás nakupují za nižší ceny. Výše slevy se odvíjí od realizovaného obrátu.



SERVIS ON-SITE A IN-TIME

K projektovým dodávkám nabízíme rozšířenou podporu a servis s garancí výměny zařízení do 48 hodin.