

R15L100-67C3(HB)

15" G-WIN IP67 Series Display



KEY FEATURES

- High Quality 15" XGA Panel, 1024 x 768 resolution, 1000 nits
- Full IP67 Dust Water-proof Protection
- Aluminum Housing with Anti-Corrosion Treatments
- Built-in ambient Light sensor
- Optical Bonding with Anti Moisture Treatments
- Anti-Shock and Vibration Standard according to IEC60068-2-27
- 5 Wire Resistive Touchscreen / Anti-Reflective Protection Glass
- 9V ~ 36V DC Isolation Wide Range Power Input
- Compliance with EN50155



SPECIFICATIONS

Display			
Resolution	1024x768	Size	15.0 inches
Contrast Ratio	2000:1	Panel Brightness	300.0 nits
Display Color	16.2M Colors	View Angles	88,88,88,88
Active Area	304.1x228.1 mm	Touch / Glass	Resistive Touch Screen Bonding With Panel Protection Glass Without touch function (Optional)
Optional function	High brightness Panel for sunlight readable (Optional)		
Mechanical			
Dimension	398 x 308 x 58 mm	Weight	4.2 kg
Mounting	VESA Mount Yoke Mount	Enclosure	Aluminum Housing
Cooling System	Fanless design		
Environment			
Operating Humidity	10% to 90% RH, Non-Condensing	Operating Temperature	-10°C to 55°C -40°C to 70°C (with intelligent heater)
Storage Temperature	-30°C to 70°C	Shock	MIL-STD-810G Method 516.6 Procedure I
Vibration	MIL-STD-810G Method 514.6 Procedure I	IP rating	IP67
Certification			
Certification	CE, FCC		
IO Ports			
Power Input	1 x M12 waterproof connector for 9~36V DC	USB Port	1x M12 type connector for Touchscreen via USB signal
Serial Port	1 x M12 type connector for Touchscreen via RS232 signal (Optional)	Video	1x M12 type connector for VGA input 1x M21 type connector for HDMI input (Optional)
Indicator	1 x LED Indicator for power 1 x LED Indicator for status		
Control			
Button	1 x Power Button 1 x Adjust up button 1 x Adjust down button		

1 x ESC (Auto) button
1 x OK (Menu) button

Accessory

Accessory

External open wire Power cable with waterproof connector
External USB cable with waterproof connector
External VGA cable with waterproof connector
Waterproof caps
VESA screws

Optional Accessory

Yoke mount stand (Optional)
100~240V AC to DC 50W Adapter with power cord (Optional)
External COM cable with waterproof connector (Optional)
External HDMI cable with waterproof connector (Optional)

System Specification

DIMENSIONS UNIT:MM

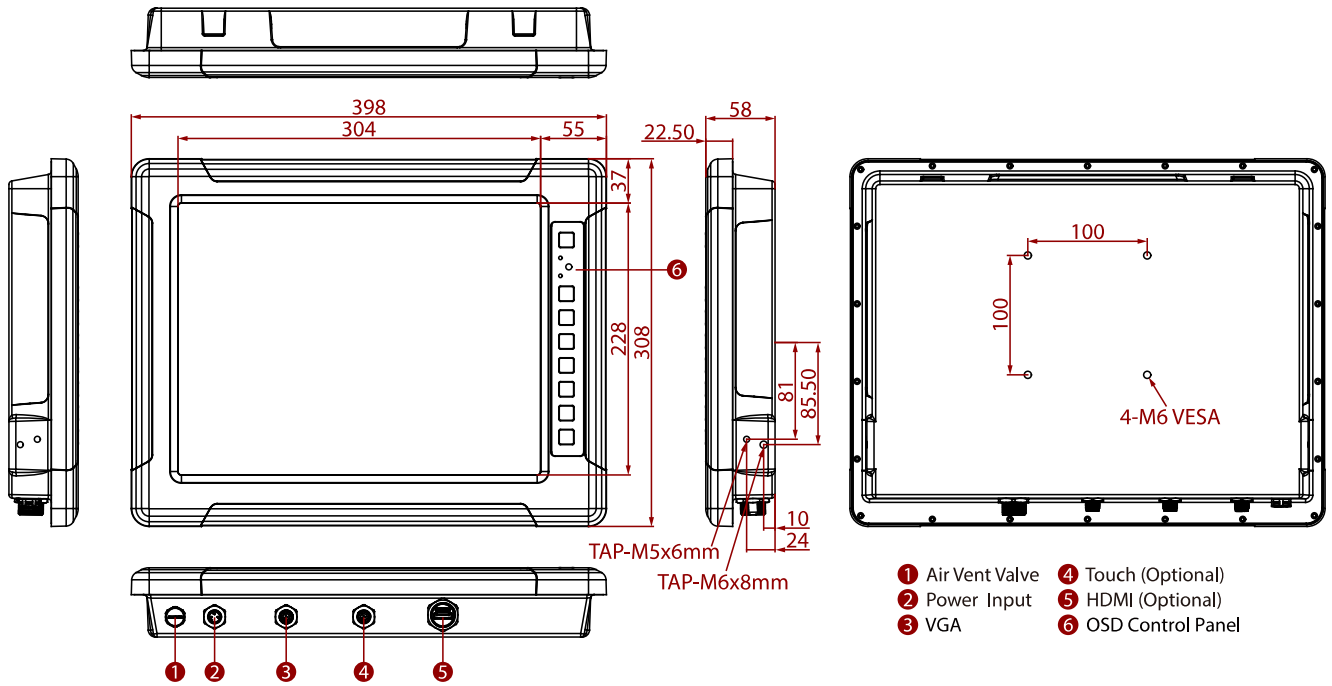

NOTE

1. This is a simplified drawing and some components are not marked in detail.
2. The product shown in this datasheet is a standard model. For diagrams that contain customized or optional I/O, please contact the Winmate Sales Team for more information.
3. All specifications are subject to change without prior notice.

Tento produkt můžete zakoupit u společnosti AutoCont IPC a.s.



AutoCont IPC a.s.

Váš dodavatel průmyslových počítačů, komponent a speciálních průmyslových IT systémů.

 Uhlířská 1064/3, 710 00 Ostrava, Česká republika

 obchod@autocont-ipc.cz

 +420 552 301 002

 www.autocont-ipc.cz



PRŮMYSLOVÉ POČÍTAČE

fanless embedded PC, do racku, ...



POČÍTAČE S DISPLEJEM

panelové PC, terminály, do vozidel, ...



AUTOMATIZACE A SBĚR DAT

převodníky, karty, moduly, switche, ...



PERIFERIE A KOMPONENTY

monitory, klávesnice, desky, skříně, ...



NOTEBOOKY A TABLETY

odolné, windows, android, IP65, ...



INFORMAČNÍ KIOSKY

interiérové, venkovní, ...



MEDICÍNSKÁ TECHNIKA

počítače, tablety, LCD, klávesnice, ...



SOFTWAREVÁ ŘEŠENÍ

pro výrobu, zaměstnance, kiosky, ...



PŘEJÍT DO E-SHOPU

eshop.autocont-ipc.cz



DOPRAVA ZDARMA

Doprava zdarma v ČR a SR při objednávce nad 10 000 Kč bez DPH nebo nad 400 EUR.



PRODLOUŽENÁ ZÁRUKA

Záruka 2 roky na vyráběné počítače s možností jejího prodloužení až na 5 let.



ODMĚNA ZA VĚRNOST

Pravidelní zákazníci u nás nakupují za nižší ceny. Výše slevy se odvíjí od realizovaného obrátu.



SERVIS ON-SITE A IN-TIME

K projektovým dodávkám nabízíme rozšířenou podporu a servis s garancí výměny zařízení do 48 hodin.