

# R15IB3S-MLA3HB

## 15" Intel® Celeron® N2930 G-WIN Defence Panel PC



### KEY FEATURES

- Build in ambient Light sensor
- High Quality 15" Panel, 1024x768 resolution, 1000 nits
- 5 Wire Resistive Touchscreen(Optional) / Anti-Reflection Protection Glass
- 802.11 a/b/g/n Wireless LAN with Antenna (Optional)
- Aluminum Housing with Anti-Corrosion Treatments
- Anti-Shock and Vibration Standard according to MIL-STD-810F/G & IEC60068-2-27
- Fanless Design
- Full IP65 Dust/water resistant Protection (Except I/O parts)
- Defence grade power connector
- Ultra Low Power and High Performance Intel® Bay Trail N2930 1.83 GHz
- Wide Range 9 to 36 V DC Input (Optional)



### SPECIFICATIONS

Display			
<b>Resolution</b>	1024x768	<b>Size</b>	15.0 inches
<b>Contrast Ratio</b>	2500:1	<b>Panel Brightness</b>	1000.0 nits
<b>View Angles</b>	88,88,88,88	<b>Active Area</b>	304.1x228.1 mm
<b>Touch / Glass</b>	AR Protection Glass 5 Wires Resistive Touch (Optional) 5 Wire Resistive with EMI Mesh Filter (Optional) EMI Glass (Optional)		
System Specification			
<b>Processor</b>	Intel Celeron N2930 1.83GHz (up to 2.16GHz)	<b>Memory</b>	1 x SO-DIMM, DDR3L 1600 MHz, 4GB 8GB (Optional)
<b>Storage</b>	1 x mSATA SSD 128GB. mSATA SSD up to 512GB. (Optional)	<b>Ethernet controller</b>	2 x Intel® Ethernet Controller
<b>Operating System</b>	Windows 10 IoT Enterprise (64 bit) (Optional) Linux Ubuntu 20.04 (Optional)	<b>WLAN</b>	Support (Optional)
<b>BT</b>	Support (Optional)		
Environment			
<b>Operating Humidity</b>	10% to 95% RH	<b>Operating Temperature</b>	-20°C~60°C
<b>Storage Temperature</b>	-30°C~70°C	<b>Shock</b>	Operating:30g for 18ms
<b>Vibration</b>	Operating: 1.60/1.96/2.18 g rms for XYZ / 5-500Hz		
Compliance			
<b>MIL-STD 461E/F/G</b>	RE101 / RE102 CE101 / CE102 CS118 with EMI Glass / Touch(Optional) RS101 / RS 103 CS101 / CS 106 / CS 109 / CS 114 / CS 115 / CS 116	<b>MIL-STD 810G</b>	Vibration Method 514.6 Humidity Method 507.4 Transit Drop Method516.5

## Certification

Certification CE, FCC

## IO Ports

USB Port 1 x USB2.0  
1 x USB3.0

Serial Port 1 x RS-232(Default)/422/485  
1 x RS-232 (Optional)

Video 1 x HDMI (Optional)

LAN 2 x RJ45

## Mechanical

Dimension 398 x 308 x 58 mm

Mounting VESA Mount

Enclosure Metal Housing with Aluminum Bezel

Cooling System Fanless Design

## Accessory

Accessory User Manual  
Driver CD and User Manual  
Touch Driver CD  
Open Wire Cable  
100~240V AC to DC Adapter  
Power Cord

## Power

Power Rating 12V DC (MIL-DTL-38999/1 connector)  
9V to 36V wide range (Optional)

## Control

Button 8 key:  
Power  
Reset  
Lock/Unlock  
Auto Dimming/Manually  
Day/Night Mode  
Brightness Up  
Brightness Down  
LED Adjustment

## DIMENSIONS UNIT:MM

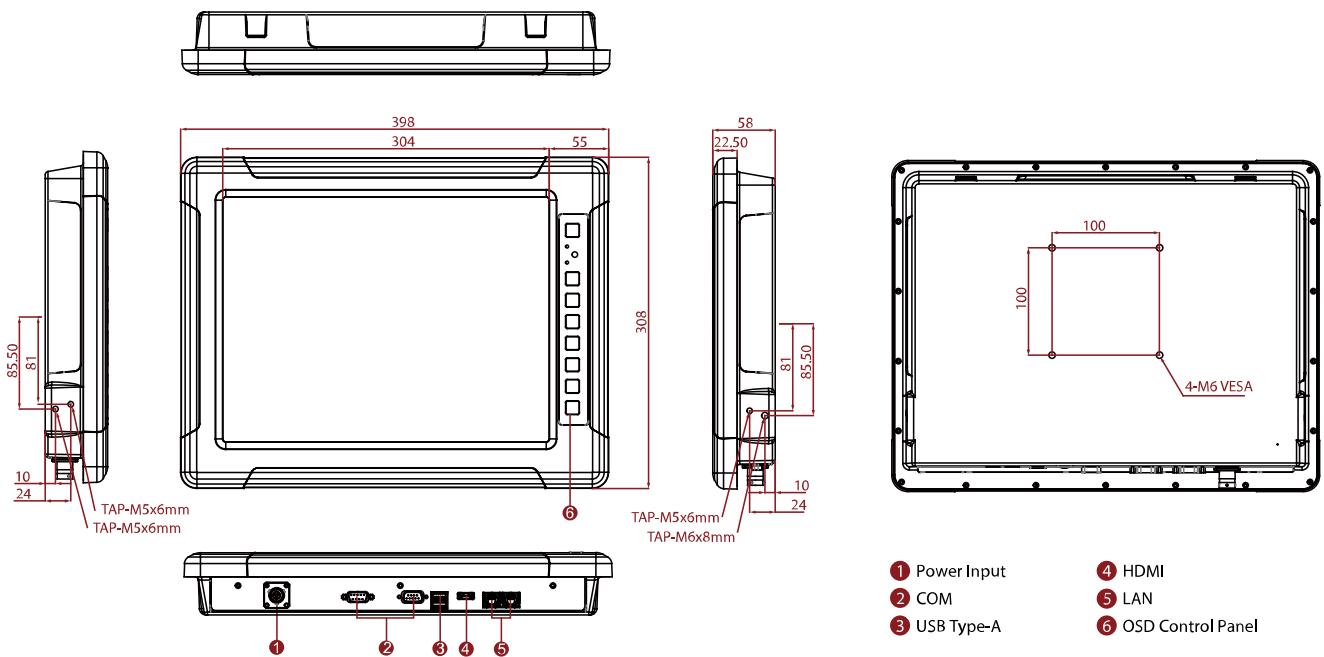

## NOTE

1. R15IB3S-MLA3HB

# Tento produkt můžete zakoupit u společnosti AutoCont IPC a.s.



## AutoCont IPC a.s.

Váš dodavatel průmyslových počítačů, komponent a speciálních průmyslových IT systémů.

 Uhlířská 1064/3, 710 00 Ostrava, Česká republika

 obchod@autocont-ipc.cz

 +420 552 301 002

 [www.autocont-ipc.cz](http://www.autocont-ipc.cz)



### PRŮMYSLOVÉ POČÍTAČE

fanless embedded PC, do racku, ...



### POČÍTAČE S DISPLEJEM

panelové PC, terminály, do vozidel, ...



### AUTOMATIZACE A SBĚR DAT

převodníky, karty, moduly, switche, ...



### PERIFERIE A KOMPONENTY

monitory, klávesnice, desky, skříně, ...



### NOTEBOOKY A TABLETY

odolné, windows, android, IP65, ...



### INFORMAČNÍ KIOSKY

interiérové, venkovní, ...



### MEDICÍNSKÁ TECHNIKA

počítače, tablety, LCD, klávesnice, ...



### SOFTWAREVÁ ŘEŠENÍ

pro výrobu, zaměstnance, kiosky, ...



### PŘEJÍT DO E-SHOPU

[eshop.autocont-ipc.cz](http://eshop.autocont-ipc.cz)



### DOPRAVA ZDARMA

Doprava zdarma v ČR a SR při objednávce nad 10 000 Kč bez DPH nebo nad 400 EUR.



### PRODLOUŽENÁ ZÁRUKA

Záruka 2 roky na vyráběné počítače s možností jejího prodloužení až na 5 let.



### ODMĚNA ZA VĚRNOST

Pravidelní zákazníci u nás nakupují za nižší ceny. Výše slevy se odvíjí od realizovaného obrátu.



### SERVIS ON-SITE A IN-TIME

K projektovým dodávkám nabízíme rozšířenou podporu a servis s garancí výměny zařízení do 48 hodin.