

R08IWK8M-RTU1GP

8.4" Intel® Core™ i5-8265U Ultra Rugged Tablet PC



KEY FEATURES

- 8th Gen. Intel® Core™ i5-8265U 1.6 GHz (turbo up to 3.9GHz) Ultra Rugged Tablet PC
- 8.4" 800 x 600 Resolution Transflective TFT-LCD Panel
- Plastic front cover and Alu-Mg Alloy rear cover with Protective Rubber
- Trusted platform module (TPM) V2.0
- Built-in Wireless / BT / GPS
- Optional 4G LTE
- Adjustable Kickstand that is convertible to a handle(Optional)



SPECIFICATIONS

Display			
Resolution	800x600	Size	8.4 inches
Contrast Ratio	600:1	Panel Brightness	600.0 nits
View Angles	75,75,60,70	Touch / Glass	Resistive Touch Screen (Optional) Protection Glass w/o Touch Function (Optional)
System Specification			
Processor	Intel Core i5-8265U 1.6GHz (up to 3.9GHz)	Memory	1 x SO-DIMM, DDR4 2400 MHz, 4GB 8GB (Optional) 16GB (Optional) 32GB (Optional)
Storage	1 x M.2 2242 SSD 128GB M.2 2242 SSD up to 512GB (Optional) M.2 2280 NVME SSD, up to 4TB (Optional)	Ethernet controller	2 x Intel® Ethernet Controller
Security	TPM 2.0	Operating System	Windows 10 IoT Enterprise (64 bit) (Optional) Linux Ubuntu 20.04 (Optional)
WLAN	Wi-Fi Support	BT	BT Support
WWAN	4G/ LTE or 3G (Optional)	GNSS	Supports GPS GLONASS, Galileo, BeiDou) (Optional)
Mechanical			
Dimension	266 x 224 x 50.4 mm	Weight	2.4 kg
Mounting	VESA Mount	Enclosure	Magnesium Alloy
Cooling System	Fanless design		
Environment			
Operating Humidity	10% to 90% RH, Non-Condensing	Operating Temperature	-10°C to 50°C (14°F to 122°F) (Battery mode) -20°C to 60°C (4°F to 158°F) (AC mode)"
Storage Temperature	-20°C to 60°C	Shock	MIL-STD-810G Method 516.6 Procedure I
Vibration	MIL-STD-810G Method 514.6 Procedure I	IP rating	IP54
Drop	MIL-STD-810G Method 516.6 Procedure IV		
Certification			
Certification	CE, FCC		
IO Ports			

USB Port	2 x USB3.2 Gen1x1 (Type-A)	Serial Port	1 x RS232/422/485 (Default RS232)
SD Card Slot	1 x Micro SD card Slot	SIM Card Slot	1 x Micro SIM card Slot
Audio	1 x Audio Combo Connector (Mic in / Line Out) 2 x Speaker	LAN	1 x Giga LAN RJ45 Connector
Indicator	1 x LED Indicator for power 1 x LED Indicator for HDD 1 x LED Indicator for Battery status 1 x LED Indicator for Wifi		
Control			
Button	1 x Power button 1 x Menu button 1 x Up button 1 x Down button 3 x Function key button		
Accessory			
Accessory	100~240V AC to 19V DC 65W Adapter Power Cord 11.1V / 5200mAh Battery Quick Start Guide Stylus	Optional Accessory	Adjustable Kickstand (Optional) Multi-functional Desktop Docking station (Optional) Vehicle Mounting Charger Kit (Optional) Car Power Charger (Optional) Hand Strap (Optional) Shoulder Strap (Optional) Soft Shell Case (Optional) Carry Bag (Optional)
Barcode Scanner			
Barcode Scanner	2D Barcode Reader (Optional)		
Camera			
Front Camera	2MP Camera (Optional)	Rear Camera	5MP Autofocus Camera (Optional)

DIMENSIONS UNIT:MM

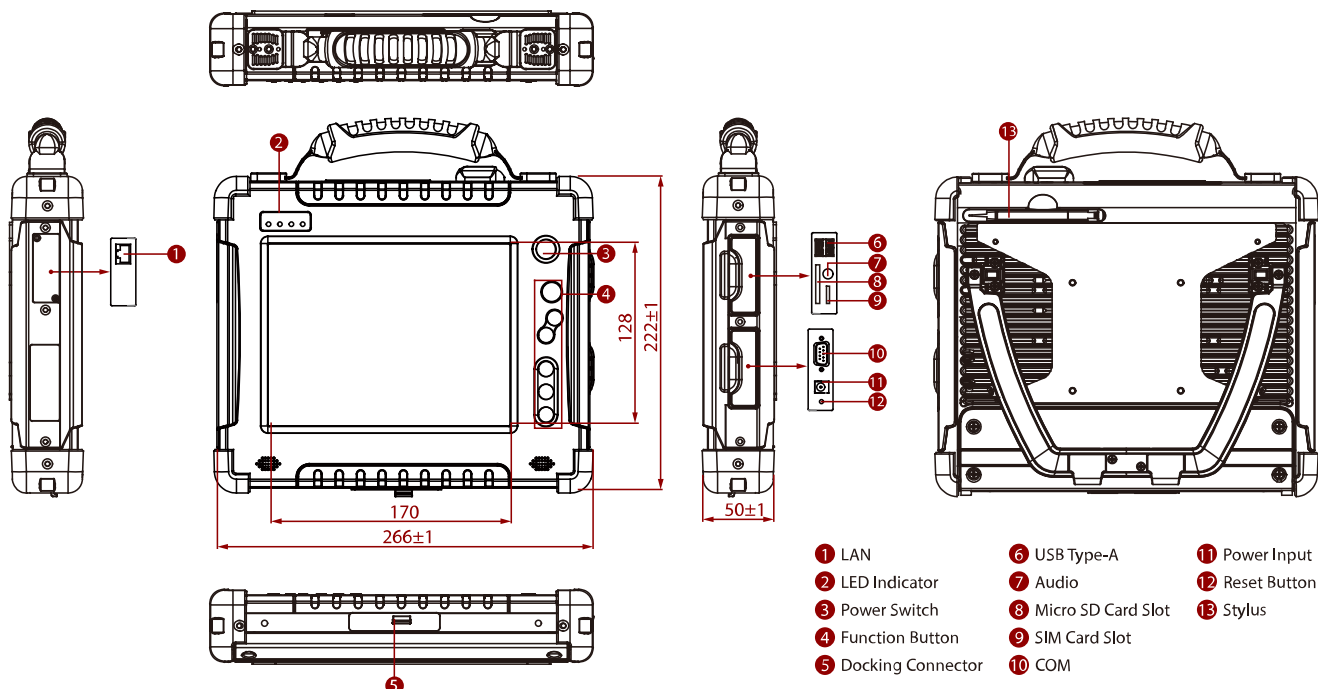

NOTE

1. Measured at dimming LCD brightness. Varies depending on the usage conditions, or when an external device is attached.
2. This is a simplified drawing and some components are not marked in detail.
3. The product shown in this datasheet is a standard model. For diagrams that contain customized or optional I/O, please contact the Winmate Sales Team for more information.

Tento produkt můžete zakoupit u společnosti AutoCont IPC a.s.



AutoCont IPC a.s.

Váš dodavatel průmyslových počítačů, komponent a speciálních průmyslových IT systémů.

 Uhlířská 1064/3, 710 00 Ostrava, Česká republika

 obchod@autocont-ipc.cz

 +420 552 301 002

 www.autocont-ipc.cz



PRŮMYSLOVÉ POČÍTAČE

fanless embedded PC, do racku, ...



POČÍTAČE S DISPLEJEM

panelové PC, terminály, do vozidel, ...



AUTOMATIZACE A SBĚR DAT

převodníky, karty, moduly, switche, ...



PERIFERIE A KOMPONENTY

monitory, klávesnice, desky, skříně, ...



NOTEBOOKY A TABLETY

odolné, windows, android, IP65, ...



INFORMAČNÍ KIOSKY

interiérové, venkovní, ...



MEDICÍNSKÁ TECHNIKA

počítače, tablety, LCD, klávesnice, ...



SOFTWAREVÁ ŘEŠENÍ

pro výrobu, zaměstnance, kiosky, ...



PŘEJÍT DO E-SHOPU

eshop.autocont-ipc.cz



DOPRAVA ZDARMA

Doprava zdarma v ČR a SR při objednávce nad 10 000 Kč bez DPH nebo nad 400 EUR.



PRODLOUŽENÁ ZÁRUKA

Záruka 2 roky na vyráběné počítače s možností jejího prodloužení až na 5 let.



ODMĚNA ZA VĚRNOST

Pravidelní zákazníci u nás nakupují za nižší ceny. Výše slevy se odvíjí od realizovaného obrátu.



SERVIS ON-SITE A IN-TIME

K projektovým dodávkám nabízíme rozšířenou podporu a servis s garancí výměny zařízení do 48 hodin.