

M101S-EX

10.1" ATEX Rugged Tablet with Intel® Core™ i5-7200U



KEY FEATURES

- Allows cross-zone operations in hazardous and explosive environments
- Ex Certificate: Class I Division 2 (CID2), ATEX/IECEX Zone 2
- 7th Gen Intel® Core™ i5-7200U Kaby lake processor
- 10.1" 1920 x 1200 IPS LED Panel with direct optical bonding
- Sunlight readable with anti-glare solution, fully ATEX tablet
- Hot-swappable battery design with optional High capacity battery pack
- IP65 waterproof and dustproof, MIL-STD-810G shock, vibration and drop resistance



SPECIFICATIONS

System Specification			
Processor	Intel Core i5-7200U 2.5GHz (up to 3.1GHz) Intel Core i5-7300U 2.6GHz (up to 3.5GHz) (Optional)	Memory	8GB DDR4 SDRAM 16GB DDR4 SDRAM (Optional)
Storage	256GB SSD Additional storage available with micro SDXC card slot 512GB SSD (Optional)	Security	Trusted Platform Module (TPM) 2.0 Kensington Lock
Operating System	Windows 10 IoT Enterprise (64 bit)	WLAN	Support
BT	Support	WWAN	4G LTE (Optional)
GNSS	GPS, GLONASS	RFID	HF RFID reader 13.56 MHz (Optional)
Sensors	Light sensor/ G-sensor / Gyro		
Camera			
Front Camera	2MP Front Camera	Rear Camera	8MP Rear Camera with auto-focus and LED light
Mechanical			
Dimension	271.8 x 197.2 x 21 mm (10.7 x 7.76 x 0.83 inches)	Weight	1.25 kg (2.75 lbs) with standard battery, 1.45 kg (3.2 lbs) with optional high capacity battery
Cooling System	Fan design		
IO Ports			
USB Port	1 x USB 3.0 (Type A), 1 x USB 3.0 (Type C)	SD Card Slot	1 x Micro SDXC slot
SIM Card Slot	1 x Micro SIM card slot	Video	1 x Micro HDMI (Optional)
Audio	1 x Audio combo 3.5mm audio combo jack Dual Digital Mic With Noise Cancellation Dual Speaker	Indicator	4x LED Indicator for Power, Battery, HDD, RF status
Docking Connector	1 x 19-pin docking connector		
Environment			
Operating Humidity	10% to 90% RH, non-condensing	Operating Temperature	-20°C to 60°C (AC mode), -10°C to 50°C (Battery mode)

Storage Temperature	-30°C to 70°C (-22°F to 158°F)	Shock	MIL-STD-810G Method 516.6 Procedure I
Vibration	MIL-STD-810G Method 514.6 Procedure I	IP rating	IP65
Drop	MIL-STD-810G Method 516.6, 4 ft		

Certification

Certification CE, FCC
 Hazardous Location Safety:
 Class I Division 2, ATEX/IECEX Zone 2

Security Function

SOTI MobiControl SOTI MobiControl Compliance **Kensington Lock** Kensington Lock Support

Control

Button 1 x Power, 1 x Home
 2 x volume key
 2 x Programmable function Keys

Power

Battery Hot-swappable 7.4V, typ. 5140 mAh LiPolymer Battery (2S1P) **Battery Operating Time** Standard. Battery: 8 hours
Power Rating 19V DC **Adapter** 100-240V, 50-60Hz / 19V DC

Accessory

Accessory Adapter and Power Cord
 Capacitive Stylus
 Standard Battery

Optional Accessory Desk Dock (Optional)
 Vehicle Dock (without VGA output) (Optional)
 Vehicle Cradle (Optional)
 Vehicle Charger (Optional)
 High Capacity Battery (Optional)
 Battery Charger (Optional)
 Hand Strap (Optional)
 Shoulder Strap (Optional)
 Carry Bag (Optional)
 VESA Mount Kit (Optional)

Barcode Scanner

Barcode Scanner 1D/2D barcode reader (Optional)

DIMENSIONS UNIT:MM

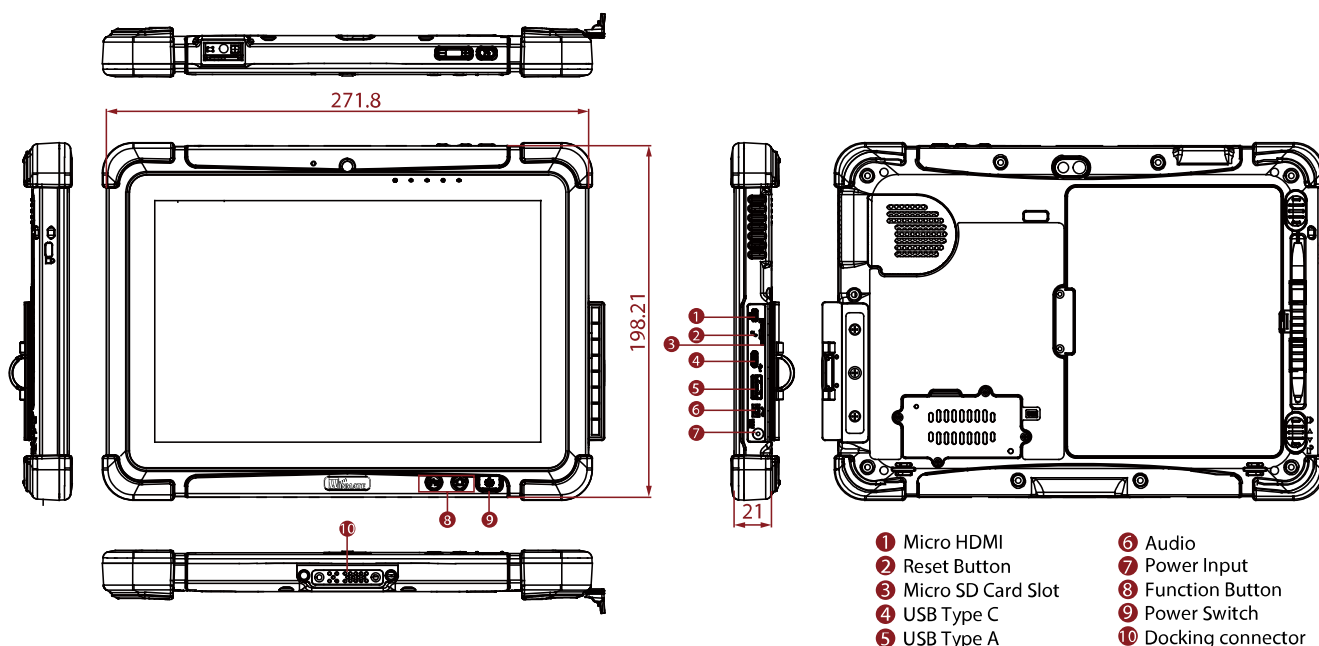

NOTE

- 1.This is a simplified drawing and some components are not marked in detail.
- 2.Please contact our sales representative if you need further product information.
- 3.All specifications are subject to change without prior notice.
- 4.The product shown in this datasheet is a standard model.For diagrams that contain customized or optional I/ O, please contact the Winmate Sales Team for more information.

Tento produkt můžete zakoupit u společnosti AutoCont IPC a.s.



AutoCont IPC a.s.

Váš dodavatel průmyslových počítačů, komponent a speciálních průmyslových IT systémů.

 Uhlířská 1064/3, 710 00 Ostrava, Česká republika

 obchod@autocont-ipc.cz

 +420 552 301 002

 www.autocont-ipc.cz



PRŮMYSLOVÉ POČÍTAČE

fanless embedded PC, do racku, ...



POČÍTAČE S DISPLEJEM

panelové PC, terminály, do vozidel, ...



AUTOMATIZACE A SBĚR DAT

převodníky, karty, moduly, switche, ...



PERIFERIE A KOMPONENTY

monitory, klávesnice, desky, skříně, ...



NOTEBOOKY A TABLETY

odolné, windows, android, IP65, ...



INFORMAČNÍ KIOSKY

interiérové, venkovní, ...



MEDICÍNSKÁ TECHNIKA

počítače, tablety, LCD, klávesnice, ...



SOFTWAREVÁ ŘEŠENÍ

pro výrobu, zaměstnance, kiosky, ...



PŘEJÍT DO E-SHOPU

eshop.autocont-ipc.cz



DOPRAVA ZDARMA

Doprava zdarma v ČR a SR při objednávce nad 10 000 Kč bez DPH nebo nad 400 EUR.



PRODLOUŽENÁ ZÁRUKA

Záruka 2 roky na vyráběné počítače s možností jejího prodloužení až na 5 let.



ODMĚNA ZA VĚRNOST

Pravidelní zákazníci u nás nakupují za nižší ceny. Výše slevy se odvíjí od realizovaného obrátu.



SERVIS ON-SITE A IN-TIME

K projektovým dodávkám nabízíme rozšířenou podporu a servis s garancí výměny zařízení do 48 hodin.