

# W24L100-SPA269-P1

## 23.8" IP69K Stainless P-Series Display



### KEY FEATURES

- 23.8" with Projected Capacitive Multi-Touch (PCAP)
- Fanless cooling system, IP69K Stainless Display
- SUS 316 / AISI 316 stainless steel for food and chemical industries
- Full IP69K waterproof enclosure
- A true flat, easy-to-clean front surface with edge-to-edge design
- Waterproof sealed conduit pipe for cable protection
- Supports VESA mount and Yoke mount stand
- Optical bonding (optional)



### SPECIFICATIONS

Display	
<b>Resolution</b>	1920x1080
<b>Contrast Ratio</b>	3000:1
<b>Display Color</b>	16.7M Colors
<b>Active Area</b>	527.04x296.46 mm
<b>Size</b>	23.8 inches
<b>Panel Brightness</b>	250 nits
<b>View Angles</b>	89,89,89,89
<b>Touch / Glass</b>	Projected Capacitive Multi Touch Screen
Mechanical	
<b>Dimension</b>	620 x 390 x 56 mm
<b>Enclosure</b>	Stainless Housing
<b>Mounting</b>	VESA Mount Yoke Mount
<b>Cooling System</b>	Fanless design
Environment	
<b>Operating Humidity</b>	10% to 90% RH, Non-Condensing
<b>Storage Temperature</b>	-20°C to 60°C
<b>Operating Temperature</b>	0°C to 45°C
<b>IP rating</b>	IP69K
Certification	
<b>Certification</b>	CE, FCC
IO Ports	
<b>USB Port</b>	1x USB type-A for touch screen control
<b>Video</b>	1x VGA 1x HDMI (Optional)
<b>Indicator</b>	1 x LED Indicator for power 1 x LED Indicator for status
Control	
<b>Button</b>	1 x Power Button 1 x Adjust up button 1 x Adjust down button 1 x ESC (Auto) button 1 x OK (Menu) button
Accessory	
<b>Accessory</b>	1 x Waterproof Conduit 1.5m 1 x Waterproof Conduit 0.3m 2 x Elbow for connect the conduit 1 x AC to DC power adapter with power cord 1 x External USB cable for touchscreen control 1 x External HDMI cable 1 x D-sub15(male) to RJ45 adapter
<b>Optional Accessory</b>	1 x Open wire cable for phoenix connector (Optional) Yoke mount stand kit (Optional)

1 x D-sub15(female) to RJ45 adapter  
 1 x External RJ45 male to male cable  
 Manual  
 VESA screws

**Power**

**Power Rating** 12V DC

**DIMENSIONS** UNIT:MM

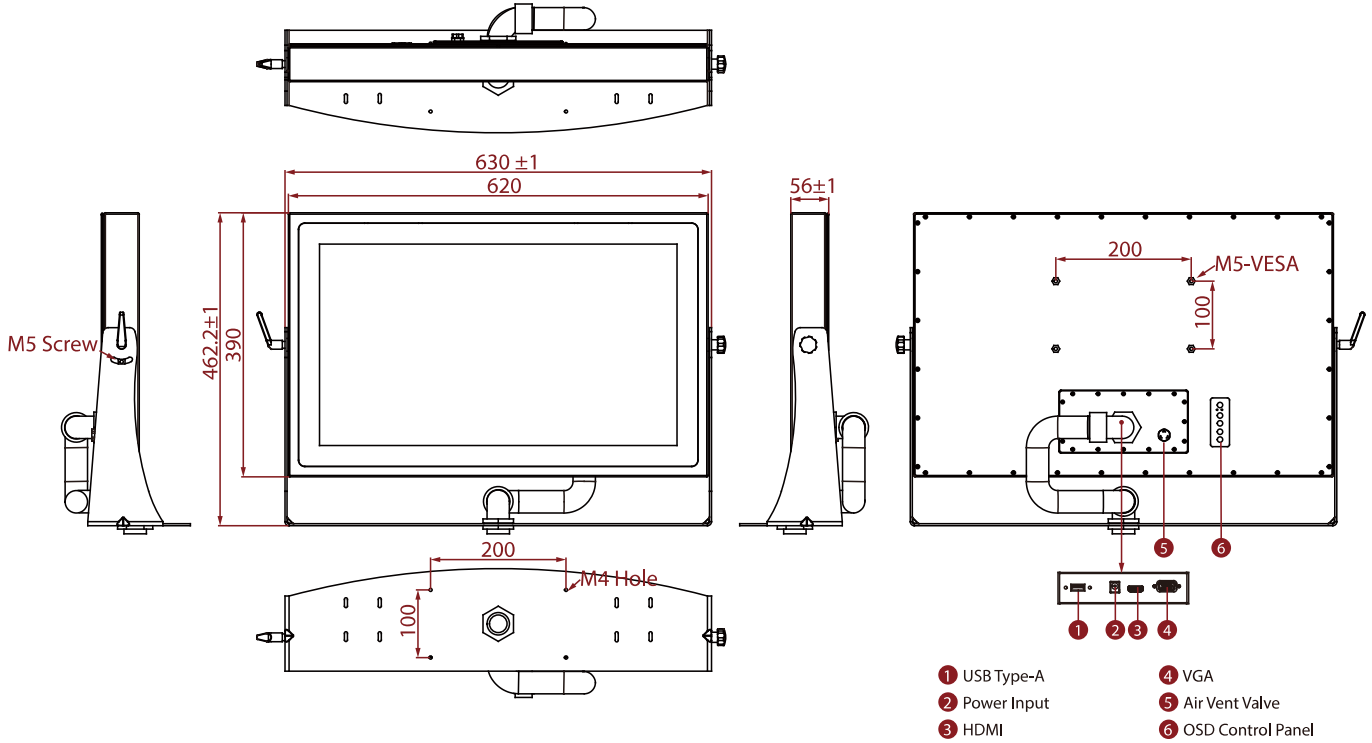

**NOTE**

1. This is a simplified drawing and some components are not marked in detail.
2. Please contact our sales representative if you need further product information.
3. All specifications are subject to change without prior notice.
4. The product shown in this datasheet is a standard model. For diagrams that contain customized or optional I/O, please contact the Winmate Sales Team for more information.

# Tento produkt můžete zakoupit u společnosti AutoCont IPC a.s.



## AutoCont IPC a.s.

Váš dodavatel průmyslových počítačů, komponent a speciálních průmyslových IT systémů.

 Uhlířská 1064/3, 710 00 Ostrava, Česká republika

 obchod@autocont-ipc.cz

 +420 552 301 002

 [www.autocont-ipc.cz](http://www.autocont-ipc.cz)



### PRŮMYSLOVÉ POČÍTAČE

*fanless embedded PC, do racku, ...*



### POČÍTAČE S DISPLEJEM

*panelové PC, terminály, do vozidel, ...*



### AUTOMATIZACE A SBĚR DAT

*převodníky, karty, moduly, switche, ...*



### PERIFERIE A KOMPONENTY

*monitory, klávesnice, desky, skříně, ...*



### NOTEBOOKY A TABLETY

*odolné, windows, android, IP65, ...*



### INFORMAČNÍ KIOSKY

*interiérové, venkovní, ...*



### MEDICÍNSKÁ TECHNIKA

*počítače, tablety, LCD, klávesnice, ...*



### SOFTWAREVÁ ŘEŠENÍ

*pro výrobu, zaměstnance, kiosky, ...*



### PŘEJÍT DO E-SHOPU

[eshop.autocont-ipc.cz](http://eshop.autocont-ipc.cz)



### DOPRAVA ZDARMA

Doprava zdarma v ČR a SR při objednávce nad 10 000 Kč bez DPH nebo nad 400 EUR.



### PRODLOUŽENÁ ZÁRUKA

Záruka 2 roky na vyráběné počítače s možností jejího prodloužení až na 5 let.



### ODMĚNA ZA VĚRNOST

Pravidelní zákazníci u nás nakupují za nižší ceny. Výše slevy se odvíjí od realizovaného obrátu.



### SERVIS ON-SITE A IN-TIME

K projektovým dodávkám nabízíme rozšířenou podporu a servis s garancí výměny zařízení do 48 hodin.