

R19IK3S-RKA3ML

19" Intel® Core™ i5-7200U Defence Console Rack Panel PC



KEY FEATURES

- 19" SXGA TFT LCD
- Intel® Core™ i5-7200U 2.5 GHz Processor
- Anti-Corrosion Housing / Fanless
- Compliant with MIL-STD-810G/F , MIL-STD-461E/F
- Flush Rack / Rack Mount Mechanical Design (9U)
- Convenient On-Screen Display Controls
- AC 110~240 V Power input default
- Isolation DC 9~36 V Power input (Optional)
- Built-in Light Sensor for auto brightness control
- Defence Grade Power Connector (MIL-DTL-38999/1)



SPECIFICATIONS

| Display | | | |
|----------------------------|--|------------------------------|---|
| Resolution | 1280x1024 | Size | 19 inches |
| Contrast Ratio | 1000:1 | Panel Brightness | 350 nits |
| View Angles | 85,85,80,80 | Active Area | 376.32x301.06 mm |
| Touch / Glass | AR Protection Glass EMI ITO Glass (Optional) 5-wire Resistive Touch (Optional) 5-wire Resistive Touch with EMI Mesh Filter (Optional) | | |
| System Specification | | | |
| Processor | Intel® Core™ i5-7200U (3M Cache, up to 3.10 GHz, BGA onboard CPU) Intel® Core™ i5-7300U (3M Cache, up to 3.50 GHz, BGA onboard CPU) | Memory | 1 x SO-DIMM, DDR4 2133 MHz, 4GB 8GB (Optional) 16GB (Optional) |
| Storage | 1 x M.2 2242 SSD 128GB M.2 2242 SSD up to 512GB (Optional) | Ethernet controller | 2 x Intel® Ethernet Controller |
| Security | TPM 2.0 | Operating System | Windows 10 IoT Enterprise (Optional) Linux Ubuntu 20.04 (Optional) |
| WLAN | Support (Optional) | BT | Support (Optional) |
| Environment | | | |
| Operating Humidity | 10% to 95% RH | Operating Temperature | -20°C~60°C |
| Storage Temperature | -30°C~70°C | | |
| Compliance | | | |
| MIL-STD 461E/F | RE101 / RE102 CE101 / CE102 with EMI Glass / Touch(Optional) RS101 / RS 103 CS101 / CS 106 / CS 109 / CS 114 / CS 115 / CS 116 | MIL-STD 810F/G | Vibration Method 514.5 Humidity Method 507.4 Transit Drop Method516.5 |
| Certification | | | |
| Certification | CE, FCC | | |

| Mechanical | | | |
|--------------|--|----------------|---|
| Dimension | 482.6 x 399.3 x 71.4 mm | Mounting | Rack Mount / Panel Mount / VESA Mount |
| Enclosure | Metal Housing with Aluminum Bezel | Cooling System | Fanless Design |
| IO Ports | | | |
| USB Port | 2 x USB 3.0 | Serial Port | 1 x RS232/422/485 (Default RS232) 1 x RS232 (Optional) |
| Video | 1 x HDMI (Optional) | LAN | 2 x RJ-45 |
| Accessory | | | |
| Accessory | User Manual (Hardcopy) CD-ROM with Driver Utility Power Cord MIL-DTL-38999/1 | | |
| Power | | | |
| Power Rating | AC 100~240V, Universal, ±10% DC 9~36V, ±10% (Optional) | | |
| Control | | | |
| Button | 8 Key OSD Control Pad: Power, Brightness DOWN, Brightness UP, Night, Day, Auto / Manual, Reset, Lock | | |

DIMENSIONS UNIT:MM

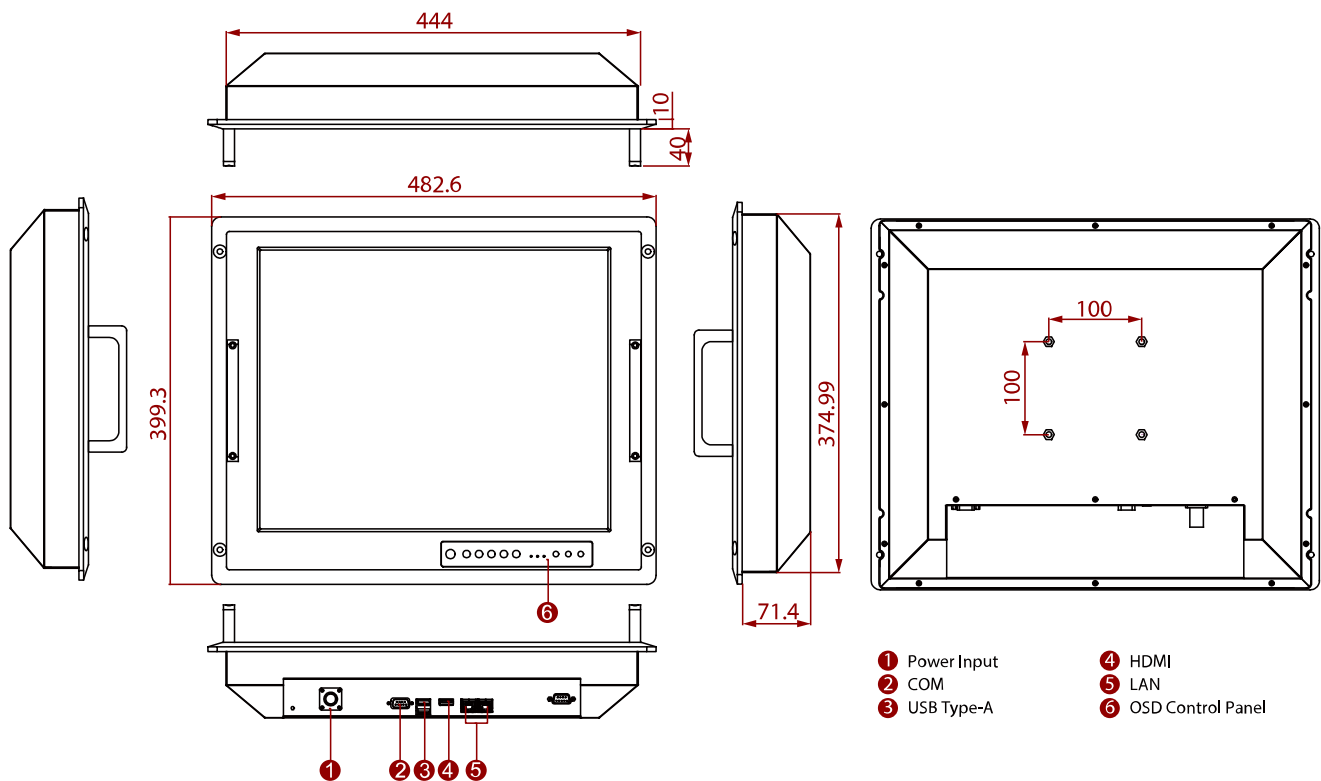

NOTE

1. This is a simplified drawing and some components are not marked in detail.
2. Please contact our sales representative if you need further product information.
3. All specifications are subject to change without prior notice.
4. The product shown in this datasheet is a standard model. For diagrams that contain customized or optional I/O, please contact the Winmate Sales Team for more information.

Tento produkt můžete zakoupit u společnosti AutoCont IPC a.s.



AutoCont IPC a.s.

Váš dodavatel průmyslových počítačů, komponent a speciálních průmyslových IT systémů.

 Uhlířská 1064/3, 710 00 Ostrava, Česká republika

 obchod@autocont-ipc.cz

 +420 552 301 002

 www.autocont-ipc.cz



PRŮMYSLOVÉ POČÍTAČE

fanless embedded PC, do racku, ...



POČÍTAČE S DISPLEJEM

panelové PC, terminály, do vozidel, ...



AUTOMATIZACE A SBĚR DAT

převodníky, karty, moduly, switche, ...



PERIFERIE A KOMPONENTY

monitory, klávesnice, desky, skříně, ...



NOTEBOOKY A TABLETY

odolné, windows, android, IP65, ...



INFORMAČNÍ KIOSKY

interiérové, venkovní, ...



MEDICÍNSKÁ TECHNIKA

počítače, tablety, LCD, klávesnice, ...



SOFTWAREVÁ ŘEŠENÍ

pro výrobu, zaměstnance, kiosky, ...



PŘEJÍT DO E-SHOPU

eshop.autocont-ipc.cz



DOPRAVA ZDARMA

Doprava zdarma v ČR a SR při objednávce nad 10 000 Kč bez DPH nebo nad 400 EUR.



PRODLOUŽENÁ ZÁRUKA

Záruka 2 roky na vyráběné počítače s možností jejího prodloužení až na 5 let.



ODMĚNA ZA VĚRNOST

Pravidelní zákazníci u nás nakupují za nižší ceny. Výše slevy se odvíjí od realizovaného obrátu.



SERVIS ON-SITE A IN-TIME

K projektovým dodávkám nabízíme rozšířenou podporu a servis s garancí výměny zařízení do 48 hodin.