

R10L100-VMT2(HB)

10.4" G-WIN VM Series Display



KEY FEATURES

- High Quality 10.4" SVGA Panel, 1024 x 768 resolution
- Front IP65 Dust/water resistant Protection (Except I/O parts)
- Aluminum Housing with Anti-Corrosion Treatments
- Anti-Shock and Vibration
- Standard according to MIL-STD-810G & IEC-60068227
- 5 Wire Resistive Touchscreen
- Anti-Reflection Protection Glass(Optional)
- 10 ~ 60V DC Isolation Wide Range Power Input. Optional Ignition on/off control function.



SPECIFICATIONS

Display			
Resolution	1024x768	Size	10.4 inches
Contrast Ratio	1000:1	Panel Brightness	350 nits
Display Color	16.2M Colors	View Angles	88,88,88,88
Active Area	210.4x157.8 mm	Touch / Glass	Resistive Touch Screen (Optional) Protection Glass Without Touch Function (Optional)
Optional function	High brightness Panel for sunlight readable (Optional)		
Mechanical			
Dimension	315 x 250 x 67 mm	Mounting	VESA Mount Yoke Mount
Enclosure	Aluminum Housing	Cooling System	Fanless design
Environment			
Operating Humidity	10% to 90% RH, Non-Condensing	Operating Temperature	-10°C to 55°C
Storage Temperature	-30°C to 70°C	Shock	MIL-STD-810G Method 516.6 Procedure I (Optional)
Vibration	MIL-STD-810G Method 514.6 Procedure I	IP rating	Front IP65
Certification			
Certification	CE, FCC		
IO Ports			
Power Input	1 x 10~60V DC, 3-Pin Terminal Block	USB Port	1x USB type-A for touch screen control (Optional)
Serial Port	1 x RS232 D-sub9 for touch screen control (Optional)	Video	1x VGA input 1x HDMI input (Optional)
Indicator	1 x LED Indicator for power 1 x LED Indicator for status		
Control			
Button	1 x Power Button 1 x Adjust up button 1 x Adjust down button 1 x ESC (Auto) button 1 x Menu button		

Accessory

Accessory Open Wire Cable with terminal block connector
External VGA cable
VESA screws

Optional Accessory Yoke mount stand (Optional)
100~240V AC to DC Adapter with power cord (Optional)
External USB/COM cable for touchscreen control (Optional)
External HDMI cable (Optional)

System Specification

DIMENSIONS UNIT:MM

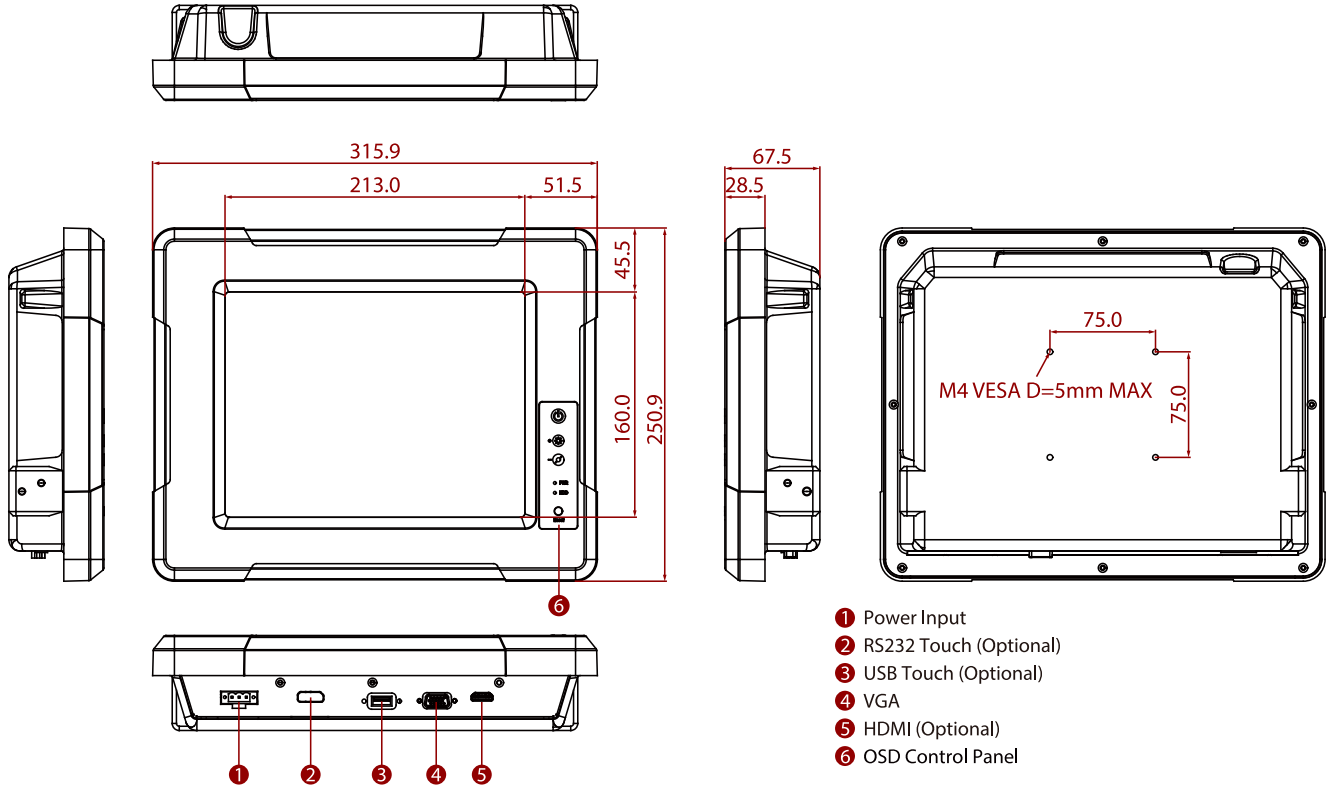

NOTE

1. This is a simplified drawing and some components are not marked in detail.
2. The product shown in this datasheet is a standard model. For diagrams that contain customized or optional I/O, please contact the Winmate Sales Team for more information.
3. All specifications are subject to change without prior notice.

Tento produkt můžete zakoupit u společnosti AutoCont IPC a.s.



AutoCont IPC a.s.

Váš dodavatel průmyslových počítačů, komponent a speciálních průmyslových IT systémů.

 Uhlířská 1064/3, 710 00 Ostrava, Česká republika

 obchod@autocont-ipc.cz

 +420 552 301 002

 www.autocont-ipc.cz



PRŮMYSLOVÉ POČÍTAČE

fanless embedded PC, do racku, ...



POČÍTAČE S DISPLEJEM

panelové PC, terminály, do vozidel, ...



AUTOMATIZACE A SBĚR DAT

převodníky, karty, moduly, switche, ...



PERIFERIE A KOMPONENTY

monitory, klávesnice, desky, skříně, ...



NOTEBOOKY A TABLETY

odolné, windows, android, IP65, ...



INFORMAČNÍ KIOSKY

interiérové, venkovní, ...



MEDICÍNSKÁ TECHNIKA

počítače, tablety, LCD, klávesnice, ...



SOFTWAREVÁ ŘEŠENÍ

pro výrobu, zaměstnance, kiosky, ...



PŘEJÍT DO E-SHOPU

eshop.autocont-ipc.cz



DOPRAVA ZDARMA

Doprava zdarma v ČR a SR při objednávce nad 10 000 Kč bez DPH nebo nad 400 EUR.



PRODLOUŽENÁ ZÁRUKA

Záruka 2 roky na vyráběné počítače s možností jejího prodloužení až na 5 let.



ODMĚNA ZA VĚRNOST

Pravidelní zákazníci u nás nakupují za nižší ceny. Výše slevy se odvíjí od realizovaného obrátu.



SERVIS ON-SITE A IN-TIME

K projektovým dodávkám nabízíme rozšířenou podporu a servis s garancí výměny zařízení do 48 hodin.