

# M140TGT

## 14" Intel® Core™ i5-1135G7 Industrial Rugged Tablet Integrated Smart Card Reader



### KEY FEATURES

- 11th Gen. Intel® Processor Family – Tiger Lake Processor industrial rugged tablet
- 14-inch tablet, 1920 x 1080 wide viewing angle LED Panel
- Optical bonding and Antiglare technology for sunlight readability
- IP65 waterproof and dustproof
- Hot-swappable battery for wholedaywork
- Integrated Smart Card Reader



### SPECIFICATIONS

Display			
<b>Bonding</b>	Optical Bonding for Sunlight Viewability	<b>Resolution</b>	1920x1080
<b>Size</b>	14 inches	<b>Contrast Ratio</b>	800:1
<b>Panel Brightness</b>	700 nits	<b>View Angles</b>	85,85,85,85
<b>Type</b>	Projected Capacitive Multi Touch		
System Specification			
<b>Processor</b>	Intel Core i5-1135G7 2.4GHz (up to 4.2GHz)	<b>Memory</b>	4GB DDR4 SDRAM 8GB DDR4 SDRAM (Optional) 16GB DDR4 SDRAM (Optional) 32GB DDR4 SDRAM (Optional)
<b>Storage</b>	128GB SSD Additional storage available with micro SDXC card slot 256GB SSD (Optional) 512GB SSD (Optional) 1TB SSD (Optional) 2TB SSD (Optional)	<b>Ethernet controller</b>	1 x RJ45-10/100/1000 Mbps LAN
<b>Security</b>	Trusted Platform Module (TPM) 2.0 Kensington Lock	<b>Operating System</b>	Windows 10 IoT Enterprise (64 bit)
<b>WLAN</b>	Support	<b>BT</b>	Support
<b>WWAN</b>	4G LTE (Optional)	<b>GNSS</b>	GPS, GLONASS (Optional)
<b>RFID</b>	HF RFID reader 13.56 MHz (Optional)	<b>Sensors</b>	Light sensor/ G-sensor / Gyro
<b>Smart Card Reader</b>	Built-in Smart Card Reader, Comply with ISO7816-1.2.3 T=1 and T=Ø protocol		
Camera			
<b>Front Camera</b>	2MP Front Camera	<b>Rear Camera</b>	8MP Rear Camera with auto-focus and LED light
Mechanical			
<b>Dimension</b>	341.91 x 224.67 x 25.4 mm	<b>Weight</b>	1.75 kg
<b>Cooling System</b>	Fan design		
IO Ports			
<b>USB Port</b>	2 x USB 3.0 (Type A), 1 x USB 3.0 (Type C)	<b>SD Card Slot</b>	1 x Micro SDXC slot
<b>SIM Card Slot</b>	1 x Nano SIM card slot	<b>Video</b>	1 x Micro HDMI (Optional)
<b>Audio</b>	1 x Audio combo 3.5mm audio combo jack Dual Digital Mic With Noise Cancellation	<b>LAN</b>	1 x RJ45-10/100/1000 GigaLAN port

	Dual Speaker		
<b>Indicator</b>	4x LED Indicator for Power, Battery, HDD, RF status	<b>Docking Connector</b>	1 x 19-pin docking connector
<b>Environment</b>			
<b>Operating Humidity</b>	10% to 90% RH, non-condensing	<b>Operating Temperature</b>	-20°C to 60°C (AC mode), -10°C to 50°C (Battery mode)
<b>Storage Temperature</b>	-30°C to 70°C (-22°F to 158°F)	<b>Shock</b>	MIL-STD-810H Method 516.8 Procedure I
<b>Vibration</b>	MIL-STD-810H Method 514.8 Procedure I	<b>IP rating</b>	IP65
<b>Drop</b>	MIL-STD-810H Method 516.8, 4 ft		
<b>Certification</b>			
<b>Certification</b>	CE, FCC		
<b>Security Function</b>			
<b>SOTI MobiControl</b>	SOTI MobiControl Compliance	<b>Kensington Lock</b>	Kensington Lock Support
<b>Control</b>			
<b>Button</b>	1 x Power, 3 x function keys		
<b>Power</b>			
<b>Battery</b>	Internal Battery: 10.8V typ. 2400 mAh Li-Ion Battery Hot-swappable 11.4V, typ. 3500 mAh Li-Ion Rechargeable Battery (3S1P)	<b>Power Rating</b>	19V DC
<b>Adapter</b>	100-240V, 50-60Hz / 19V DC		
<b>Accessory</b>			
<b>Accessory</b>	Adapter and Power Cord Standard Battery Capacitive Stylus	<b>Optional Accessory</b>	Kickstand (Optional) Vehicle Charger (Optional) Battery Charger (Optional) Shoulder Strap (Optional) Carry Bag (Optional)
<b>Barcode Scanner</b>			

## DIMENSIONS UNIT:MM

### 14" Windows Rugged Table

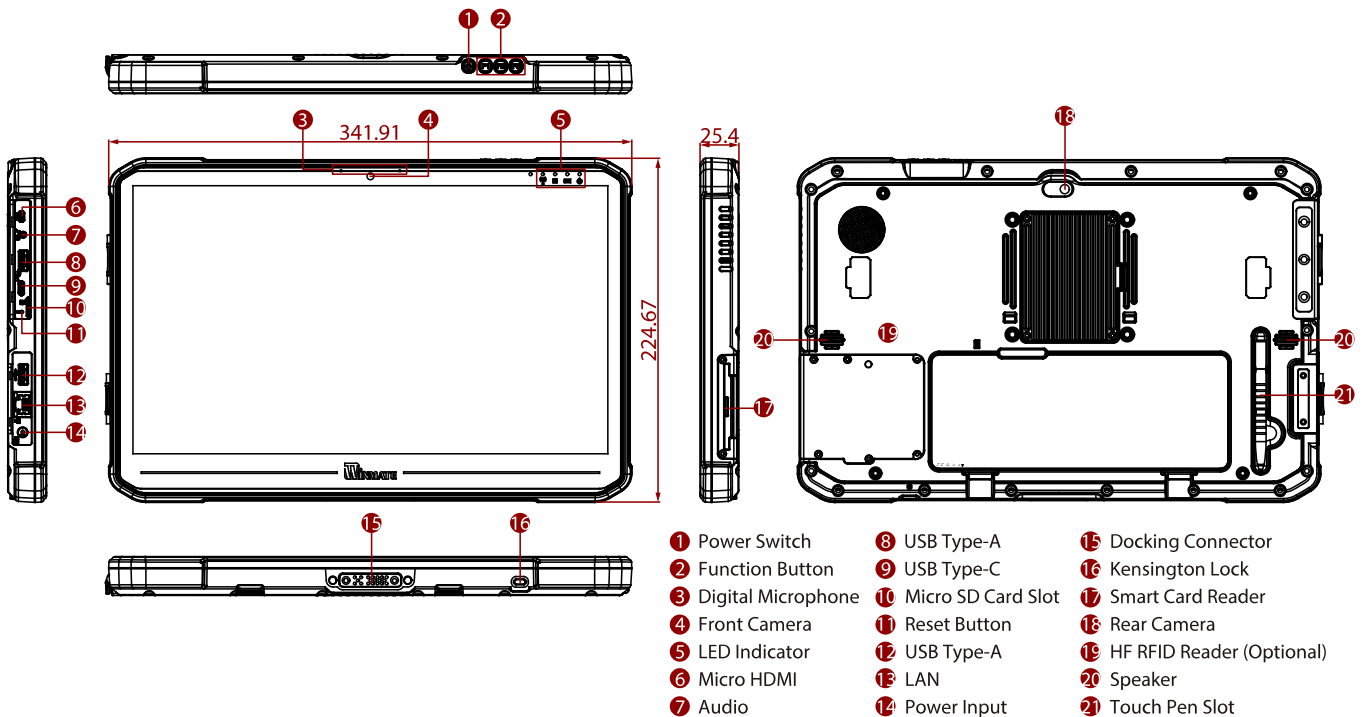

## NOTE

1. This is a simplified drawing and some components are not marked in detail.
2. Please contact our sales representative if you need further product information.
3. All specifications are subject to change without prior notice.
4. The product shown in this datasheet is a standard model. For diagrams that contain customized or optional I/O, please contact the Winmate Sales Team for more information.

# Tento produkt můžete zakoupit u společnosti AutoCont IPC a.s.



## AutoCont IPC a.s.

Váš dodavatel průmyslových počítačů, komponent a speciálních průmyslových IT systémů.

 Uhlířská 1064/3, 710 00 Ostrava, Česká republika

 [obchod@autocont-ipc.cz](mailto:obchod@autocont-ipc.cz)

 +420 552 301 002

 [www.autocont-ipc.cz](http://www.autocont-ipc.cz)



### PRŮMYSLOVÉ POČÍTAČE

*fanless embedded PC, do racku, ...*



### POČÍTAČE S DISPLEJEM

*panelové PC, terminály, do vozidel, ...*



### AUTOMATIZACE A SBĚR DAT

*převodníky, karty, moduly, switche, ...*



### PERIFERIE A KOMPONENTY

*monitory, klávesnice, desky, skříně, ...*



### NOTEBOOKY A TABLETY

*odolné, windows, android, IP65, ...*



### INFORMAČNÍ KIOSKY

*interiérové, venkovní, ...*



### MEDICÍNSKÁ TECHNIKA

*počítače, tablety, LCD, klávesnice, ...*



### SOFTWAREVÁ ŘEŠENÍ

*pro výrobu, zaměstnance, kiosky, ...*



### PŘEJÍT DO E-SHOPU

[eshop.autocont-ipc.cz](http://eshop.autocont-ipc.cz)



### DOPRAVA ZDARMA

Doprava zdarma v ČR a SR při objednávce nad 10 000 Kč bez DPH nebo nad 400 EUR.



### PRODLOUŽENÁ ZÁRUKA

Záruka 2 roky na vyráběné počítače s možností jejího prodloužení až na 5 let.



### ODMĚNA ZA VĚRNOST

Pravidelní zákazníci u nás nakupují za nižší ceny. Výše slevy se odvíjí od realizovaného obrátu.



### SERVIS ON-SITE A IN-TIME

K projektovým dodávkám nabízíme rozšířenou podporu a servis s garancí výměny zařízení do 48 hodin.