

FM07A

7"Android Vehicle Mounted Computer with NXP i.MX6



KEY FEATURES

- Android-based i.MX 6 Dual Core 1 GHz Processor Android Vehicle Mounted Computer
- 7" 1024 x 600 panel with projected capacitive Multi-Touch screen
- Wide power input 9-24V DC with ignition
- M12 waterproof connectors , IP65 waterproof and dustproof
- Shock and vibration resistance according to MIL-STD-810G



SPECIFICATIONS

Display			
Resolution	1024x600	Size	7.0 inches
Contrast Ratio	700:1	Panel Brightness	1000 nits
View Angles	75,75,75,70	Touch / Glass	Projected Capacitive Multi Touch Screen
System Specification			
Processor	NXP i.MX6 Dual Core, 1.0GHz	Memory	1GB 2GB (Optional)
Storage	Onboard 16GB eMMC Onboard 32GB eMMC (Optional)	Operating System	Linux Ubuntu 18.04 (Optional) Android 6.0 (Optional) Debian 7.0 (Optional) Linux 4.1.15 QT 5.5 (Optional)
Environment			
Operating Humidity	10% to 95% RH	Operating Temperature	-20°C to 60°C
Storage Temperature	-20°C to 60°C	Shock	MIL-STD-810G Method 516.6 Procedure I, 30 g for 18 ms
Vibration	MIL-STD-810G Method 514.6 Procedure I, 1.60/ 1.96/ 2.18 g rms for XYZ/ 5-500 Hz	IP rating	IP65, Dustproof and Waterproof
Certification			
Certification	CE, FCC, E-mark		
IO Ports			
USB Port	2 x USB for DB9	Serial Port	1 x COM Port
SIM Card Slot	1 x SIM Card Slot	Audio	1x Speaker
LAN	1 x Gigabit Ethernet LAN 10/100/100 Mbps (M12 type)	Front Control	5 x Function Key
Indicator	Power, HD	DIDO	DIDO (5XDI ; 3XDO)
CANBUS	1 x CANBus		
Control			
Button	1 x Power Button, 5x Function Button (Programmable Function Key Configured by Winset)		
Mechanical			
Dimension	188.75 x 144.75 x 39.5 mm	Mounting	RAM Mount/ VESA Mount

Cooling System Fanless Design

Accessory

Accessory

User Guide
Driver CD
M12 LAN Cable, 1.8m
RS-232 Cable, 1.8m
M12 Power Cable, 1.8m
USB Cable, 0.3m
CANBus Cable, 1.8m
Wi-Fi Antenna
Power Converter Cable
Power Adapter

Optional Accessory

WWAN Antenna x 2 (Optional)
Audio Cable, 0.3m (Optional)
GPS Antenna, 3m (Optional)

Power

Power Rating 9V-24V, with ignition control

DIMENSIONS UNIT:MM

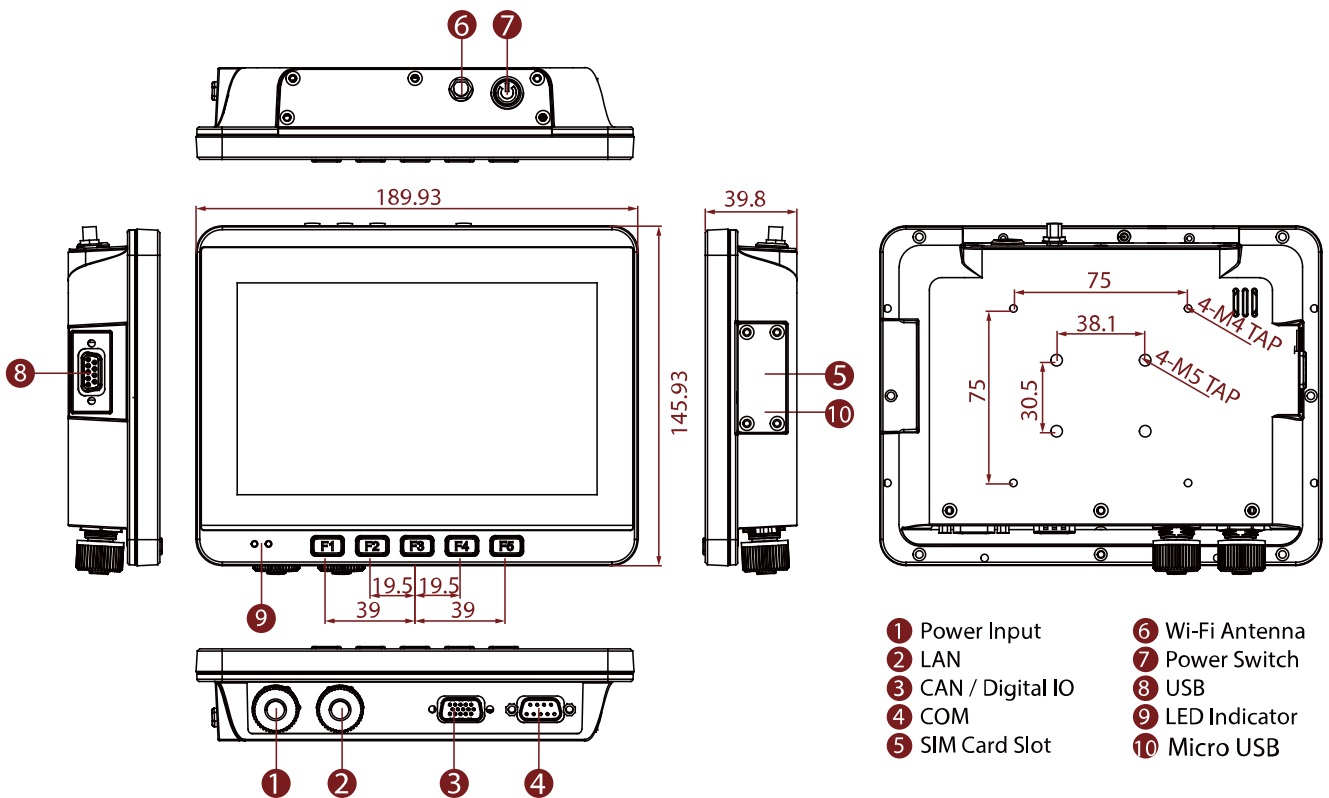

NOTE

1. Total usable memory will be less dependent upon actual system configuration.
2. Length measurements do not include protrusions. Weight varies with options.
3. Accessories may vary depending on your configuration.
4. This is a simplified drawing and some components are not marked in detail.
5. The product shown in this datasheet is a standard model. For diagrams that contain customized or optional I/O, please contact the Winmate Sales Team for more information.

Tento produkt můžete zakoupit u společnosti AutoCont IPC a.s.



AutoCont IPC a.s.

Váš dodavatel průmyslových počítačů, komponent a speciálních průmyslových IT systémů.

 Uhlířská 1064/3, 710 00 Ostrava, Česká republika

 obchod@autocont-ipc.cz

 +420 552 301 002

 www.autocont-ipc.cz



PRŮMYSLOVÉ POČÍTAČE

fanless embedded PC, do racku, ...



POČÍTAČE S DISPLEJEM

panelové PC, terminály, do vozidel, ...



AUTOMATIZACE A SBĚR DAT

převodníky, karty, moduly, switche, ...



PERIFERIE A KOMPONENTY

monitory, klávesnice, desky, skříně, ...



NOTEBOOKY A TABLETY

odolné, windows, android, IP65, ...



INFORMAČNÍ KIOSKY

interiérové, venkovní, ...



MEDICÍNSKÁ TECHNIKA

počítače, tablety, LCD, klávesnice, ...



SOFTWAREVÁ ŘEŠENÍ

pro výrobu, zaměstnance, kiosky, ...



PŘEJÍT DO E-SHOPU

eshop.autocont-ipc.cz



DOPRAVA ZDARMA

Doprava zdarma v ČR a SR při objednávce nad 10 000 Kč bez DPH nebo nad 400 EUR.



PRODLOUŽENÁ ZÁRUKA

Záruka 2 roky na vyráběné počítače s možností jejího prodloužení až na 5 let.



ODMĚNA ZA VĚRNOST

Pravidelní zákazníci u nás nakupují za nižší ceny. Výše slevy se odvíjí od realizovaného obrátu.



SERVIS ON-SITE A IN-TIME

K projektovým dodávkám nabízíme rozšířenou podporu a servis s garancí výměny zařízení do 48 hodin.