

E500QK-ML

5" Qualcomm® Snapdragon™ 660 Defence Rugged Handheld Computer



KEY FEATURES

- Qualcomm® Snapdragon™ 660 (Octa-core 2.2 GHz), Defence Rugged Handheld Computer
- 5" 1280 x 720 Panel with direct optical bonding
- IP67 waterproof and dustproof
- 8MP Front(Default) / 13MP Rear Camera(Optional)
- With 19 keypad include power key
- With Defence Standard Connector (USB + Power, Optional LAN & Audio)



SPECIFICATIONS

Display			
Resolution	1280x720	Size	5 inches
Contrast Ratio	800:1	Panel Brightness	500 nits
View Angles	80,80,80,80	Type	Projected Capacitive Multi Touch
Touch Mode	Support Hand / Gloves and Rain Mode	Bonding	Optical Bonding for Sunlight Viewability
System Specification			
Processor	Qualcomm® Snapdragon™ 660 (Octa-Core 2.2 GHz)	Memory	3GB
Storage	32GB	Operating System	Android 9.0
WLAN	Support	BT	Support
GNSS	GPS/AGPS	RFID	NFC (Read / Write, Peer to Peer mode) (Optional)
Sensors	Ambient Light Sensor, E-Compass, Gyro, Acceleration Sensors		
Camera			
Front Camera	8MP Camera	Rear Camera	13MP Camera with LED Auxiliary Light (Auto Focus)
Mechanical			
Dimension	192 x 92 x 29.25 mm	Weight	370g
IO Ports			
USB Port	1 x USB 3.0 Type C OTG (support charging)	SD Card Slot	1 x Internal non-accessible Micro SD Card Slot
Audio	1 x Built-in Mic 1 x Speaker	Expansion Port	Military Connector (Optional)
Indicator	1 x LED Indicator		
Environment			
Operating Humidity	5% to 95% RH, Non-Condensing	Operating Temperature	-10°C to 50°C (Battery mode)
Storage Temperature	-30°C to 70°C	Shock	MIL-STD-810G Method 516.6 Procedure I
Vibration	MIL-STD-810G Method 514.6 Procedure I	IP rating	IP67, Compliance IEC60592
Drop	MIL-STD-810G Method 516.6, 5 ft		
Certification			

Certification	CE, FCC		
Control			
Button	On-screen QWERTY Keyboard 1 x 19 Physical Keypad Include Power Key 1 x Volume +/-, 2 x Function Button		
Power			
Battery	3.7V 3900mAh Nonremovable Battery	Battery Operating Time	20Hr
Power Rating	5V	Adapter	5V 1A Adapter with USB TypeC
Security Function			
SOTI MobiControl	SOTI MobiControl Compliance		
Accessory			
Accessory	Universal Adapter USB Type-C Cable	Optional Accessory	Micro SD Card

DIMENSIONS UNIT:MM

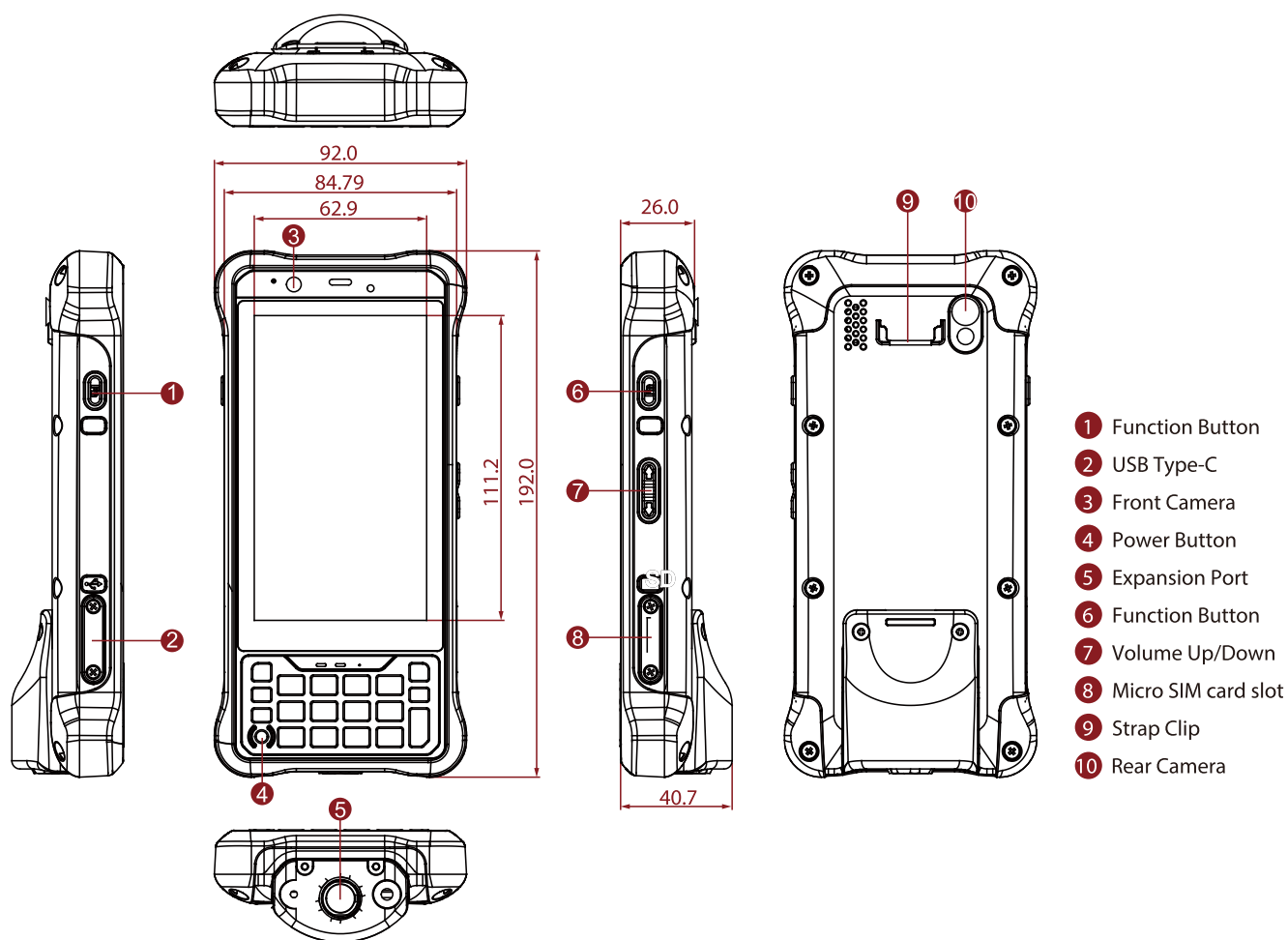

NOTE

1. Total usable memory will be less dependent upon actual system configuration.
2. Computrace theft protection is available upon request.
3. Length measurements do not include protrusions. Weight varies with options and a digitizer pen.
4. Measured at dimming LCD brightness. Varies depending on the usage conditions, or when an external device is attached.
5. Accessories and integrated options may vary depending on your configuration.
6. This is a simplified drawing, and some components are not marked in detail.
7. The product shown in this datasheet is a standard model. For diagrams that contain customized or optional I/O, please contact the Winmate Sales Team for more information.

Tento produkt můžete zakoupit u společnosti AutoCont IPC a.s.



AutoCont IPC a.s.

Váš dodavatel průmyslových počítačů, komponent a speciálních průmyslových IT systémů.

 Uhlířská 1064/3, 710 00 Ostrava, Česká republika

 obchod@autocont-ipc.cz

 +420 552 301 002

 www.autocont-ipc.cz



PRŮMYSLOVÉ POČÍTAČE

fanless embedded PC, do racku, ...



POČÍTAČE S DISPLEJEM

panelové PC, terminály, do vozidel, ...



AUTOMATIZACE A SBĚR DAT

převodníky, karty, moduly, switche, ...



PERIFERIE A KOMPONENTY

monitory, klávesnice, desky, skříně, ...



NOTEBOOKY A TABLETY

odolné, windows, android, IP65, ...



INFORMAČNÍ KIOSKY

interiérové, venkovní, ...



MEDICÍNSKÁ TECHNIKA

počítače, tablety, LCD, klávesnice, ...



SOFTWAREVÁ ŘEŠENÍ

pro výrobu, zaměstnance, kiosky, ...



PŘEJÍT DO E-SHOPU

eshop.autocont-ipc.cz



DOPRAVA ZDARMA

Doprava zdarma v ČR a SR při objednávce nad 10 000 Kč bez DPH nebo nad 400 EUR.



PRODLOUŽENÁ ZÁRUKA

Záruka 2 roky na vyráběné počítače s možností jejího prodloužení až na 5 let.



ODMĚNA ZA VĚRNOST

Pravidelní zákazníci u nás nakupují za nižší ceny. Výše slevy se odvíjí od realizovaného obrátu.



SERVIS ON-SITE A IN-TIME

K projektovým dodávkám nabízíme rozšířenou podporu a servis s garancí výměny zařízení do 48 hodin.