

# Rugged Tablet PC 7"

M9020

## Product Features:

- 7" High Quality 1024 x 600 Resolution LED Panel
- Intel® Atom Dual Core N2600 1.6GHz with Intel® NM10 Chipset
- 1 x DDR3 SO-DIMM RAM 4GB (Wide Temperature)
- Meet MIL-STD-810G Shock, Vibration and Drop Standard
- Built-in 802.11 a/b/g/n Wifi card and Bluetooth 4.0 (Class II) Module
- 3100 mAh Li-ion 7.4V Battery x 2
- CMOS 2D barcode scanner (Reads 1D and 2D barcodes)
- Full QWERTY Keyboard (5 programmable function keys)
- CID2 (By Request)
- UHR RFID (By Request)



Main Unit



Docking (Optional)

## Product Specifications:

System Specification	Processor	Intel® Atom™ Processor N2600 1.6 GHz
	System Memory	4GB DDR3 SO-DIMM RAM (Wide Temperature)
	Storage	64GB mSATA SSD (Wide Temperature, upgradable to 512GB)
	Operating System	Windows Embedded Standard WS7P
Display Specification	Size	7"
	Resolution	1024 x 600
	Brightness	900nit (typ.)
	Touch	4W Resistive Touch (GFG)
	Sensors	Light sensor for auto backlight adjustment Position sensor (accelerometer) for portrait or landscape screen orientation
Wireless Communication	Wireless	802.11 a/b/g/n WiFi Card (Cisco® Compatible Extensions (CCXv4)) Support Infrastructure and ad hoc (Client Mode)
	Bluetooth	Class 2 Bluetooth 4.0 (compliant 3.0 and 2.1 + EDR support)
	WWAN	Optional LTE (Sierra MC7304 or MC7354)
	GPS	Built-in Neo-6 GPS module
Mechanical and Environment	Dimensions (W x L x H)	229.75 x 183 x 54 mm
	Weight	1.43 kg
	Operation Temperature	-20°C to 60°C (AC mode), -20°C to 50°C (Battery mode)
	Operation Humidity	5~95% RH (non condensing)
	IP Proof	IP67
I/O Connectors	Certifications	CE / FCC / UL
	External I/O	1 x USB 2.0 A Type 1 x RS232 1 x Headset jack 1 x 2.5Ø DC Power Input 1 x Micro SD card slot (up to 32GB)
Power Management	Expansion Pots (Pin Headers for I/O Customization)	4 x USB 2.0 1 x power output 5V 2A 1 x VGA (SVGA Resolution) 4 x RS-232
	Power input	19V DC in
	Battery Operating Time	7 hours**
	Adapter	65W
Field Service Features	Camera	2M pixel camera front side; 5M rear camera with autofocus and flash light

\*Note: this is a simplified drawing and some components are not marked in detail. Please contact our sales representative if you need further product information.

\*\*Note: Measured at dimming LCD brightness. Varies depending on the usage conditions, or when an external device is attached.

## Dimensions (Main unit with docking) :

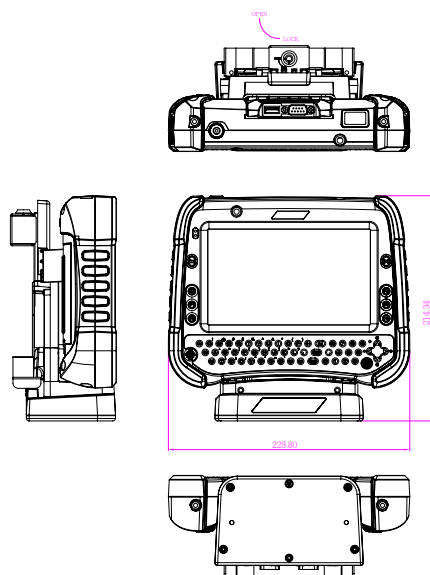

Accessories	
1.	19V 65W Power Adapter x 1
2.	Power Cord x 1
3.	Standard Battery x 2
4.	M9020 Quick Start Guide x 1
5.	Manual & Driver CD x 1
6.	Stylus Pen x1
7.	Hand Strap

Order Information	
M9020	Basic
M9020-LE	4G/LTE for Europe
M9020-LA	4G/LTE for North America

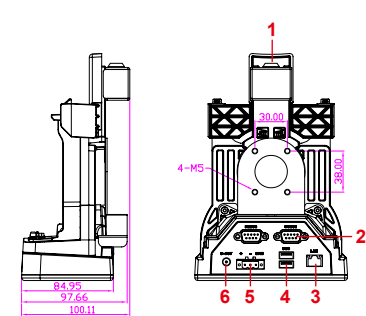

1. Lock
2. RS-232 Connectors
3. RJ-45 Connector
4. USB Ports
5. Bare leads DC connector
6. Power Connector

Release Date  
Jul.20.2016

# Tento produkt můžete zakoupit u společnosti AutoCont IPC a.s.



## AutoCont IPC a.s.

Váš dodavatel průmyslových počítačů, komponent a speciálních průmyslových IT systémů.

 Uhlířská 1064/3, 710 00 Ostrava, Česká republika

 [obchod@autocont-ipc.cz](mailto:obchod@autocont-ipc.cz)

 +420 552 301 002

 [www.autocont-ipc.cz](http://www.autocont-ipc.cz)



### PRŮMYSLOVÉ POČÍTAČE

*fanless embedded PC, do racku, ...*



### POČÍTAČE S DISPLEJEM

*panelové PC, terminály, do vozidel, ...*



### AUTOMATIZACE A SBĚR DAT

*převodníky, karty, moduly, switche, ...*



### PERIFERIE A KOMPONENTY

*monitory, klávesnice, desky, skříně, ...*



### NOTEBOOKY A TABLETY

*odolné, windows, android, IP65, ...*



### INFORMAČNÍ KIOSKY

*interiérové, venkovní, ...*



### MEDICÍNSKÁ TECHNIKA

*počítače, tablety, LCD, klávesnice, ...*



### SOFTWAREVÁ ŘEŠENÍ

*pro výrobu, zaměstnance, kiosky, ...*



### PŘEJÍT DO E-SHOPU

[eshop.autocont-ipc.cz](http://eshop.autocont-ipc.cz)



### DOPRAVA ZDARMA

Doprava zdarma v ČR a SR při objednávce nad 10 000 Kč bez DPH nebo nad 400 EUR.



### PRODLOUŽENÁ ZÁRUKA

Záruka 2 roky na vyráběné počítače s možností jejího prodloužení až na 5 let.



### ODMĚNA ZA VĚRNOST

Pravidelní zákazníci u nás nakupují za nižší ceny. Výše slevy se odvíjí od realizovaného obrátu.



### SERVIS ON-SITE A IN-TIME

K projektovým dodávkám nabízíme rozšířenou podporu a servis s garancí výměny zařízení do 48 hodin.