

M133WK

13.3" Intel® Core™ i5-8265U Ultra Rugged Tablet PC



KEY FEATURES

- Intel® Core™ i5-8265U Whiskey Lake processor
- 13.3" 1920 x 1080 IPS wide viewing angle LED Panel
- Magnesium alloy housing with all-around elastomeric rubber
- Built-in kickstand usable as carrying handle (indefinitely adjustable)
- Cold swap Battery Pack
- IP65 waterproof and dustproof
- Optical bonding technology
- TPM 2.0



SPECIFICATIONS

Display			
Resolution	1920x1080	Size	13.3 inches
Contrast Ratio	1000:1	Panel Brightness	500 nits
View Angles	89,89,89,89	Bonding	Optical Bonding for Sunlight Viewability
System Specification			
Processor	Intel® Core™ i5-8265U, 1.60 GHz (up to 3.90 GHz)	Memory	4GB SODIMM DDR4-2400 8GB SODIMM DDR4-2400 (Optional) 16GB SODIMM DDR4-2400 (Optional)
Storage	Storage 1: 1 x 128GB M.2 SSD Storage 1: Up to 512GB M.2 SSD (Optional) Storage 2: Up to 512GB M.2 SSD (Optional)	Ethernet controller	1 x RJ45-10/100/1000 Mbps LAN
Security	Trusted Platform Module (TPM) 2.0 Kensington Lock	Operating System	Windows 10 IoT Enterprise
WLAN	802.11 a/b/g/n/ac	BT	BT Support
WWAN	4G LTE (Optional)	GNSS	GPS/GLONASS (Optional)
Sensors	Light sensor/ g-sensor / Gyro / E-compass		
Mechanical			
Dimension	338.2 x 240 x 30 mm (13.3 x 9.4 x 1.18 inches)	Weight	2.2kg (w/ kickstand)
Cooling System	Fanless thermal design		
IO Ports			
USB Port	4 x USB 3.0 Type A, 1 x USB 3.1 Type C	SD Card Slot	1 x SDXC Slot
Audio	1 x built-in Digital Mic with Noise Cancellation 2 x 1 watt speaker	LAN	1 x RJ45-10/100/1000 Mbps LAN
Indicator	4x LED Indicator for Power, Battery, SSD, RF status	Docking Connector	1 x Docking connector
Environment			
Operating Humidity	30% to 80% RH, non-condensing	Operating Temperature	-10°C to 50°C (14°F to 122°F)
Storage Temperature	-20°C to 60°C (-4°F to 140°F)	Shock	MIL-STD-810G Method 516.6 Procedure I
Vibration	MIL-STD-810G Method 514.6 Procedure I	IP rating	IP65 certified, dustproof and waterproof

Drop MIL-STD-810G Method 516.6, 4 ft

Certification

Certification CE, FCC

Security Function

Kensington Lock Kensington Lock Support

Control

Button 1 x Power, 1 x menu,
3 x Programmable Function Keys

Power

Battery 15.4V, typ. 5900 mAh Li-Polymer Battery (4S1P)

Battery Operating Time More than 10 hours (BAPCo TabletMark v3)

Power Rating 19V DC

Adapter 100-240V, 50-60Hz / 19V DC

Accessory

Accessory Adapter and Power Cord
Standard Battery
Stylus
Stand with Integrated Handle

Optional Accessory VESA Mounting Kit
VESA Mounting Kit 2
RAM Mounting Kit
Vehicle Charger

DIMENSIONS UNIT:MM

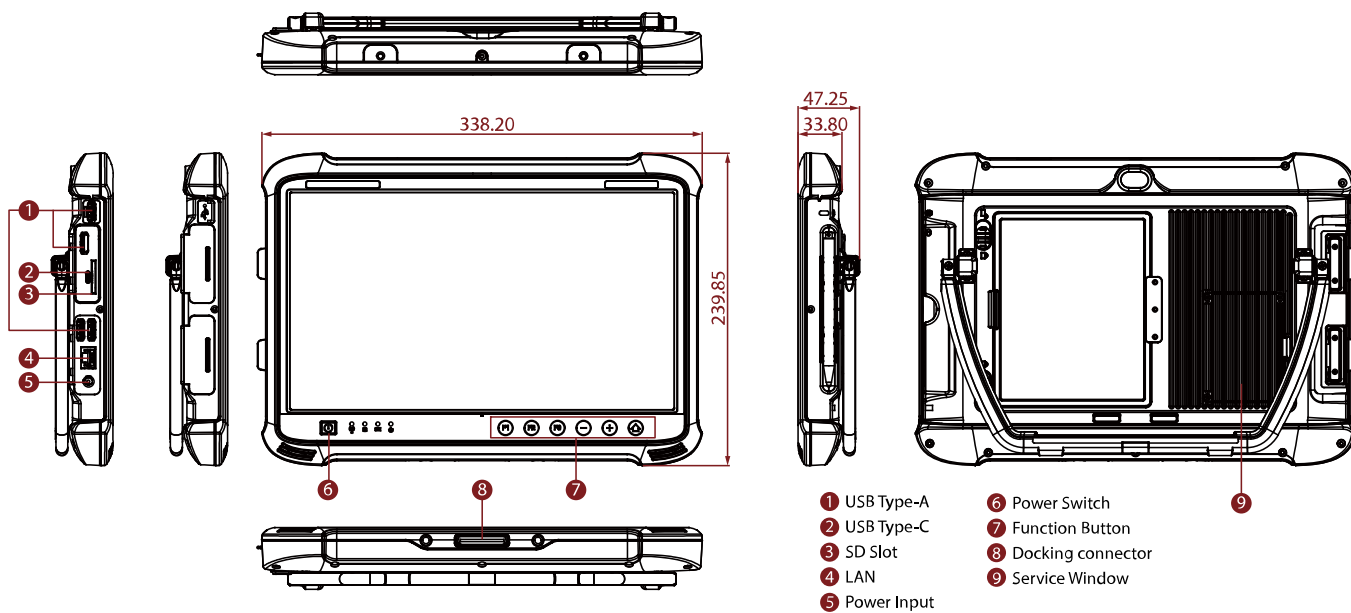

NOTE

1. Total usable memory will be less dependent upon actual system configuration.
2. TPM 2.0 is available upon request.
3. Length measurements do not include protrusions. Weight varies with options.
4. Measured at dimming LCD brightness. Varies depending on the usage conditions, or when an external device is attached.
5. This is a simplified drawing and some components are not marked in detail.
6. The product shown in this datasheet is a standard model. For diagrams that contain customized or optional I/O, please contact the Winmate Sales Team for more information.

Tento produkt můžete zakoupit u společnosti AutoCont IPC a.s.



AutoCont IPC a.s.

Váš dodavatel průmyslových počítačů, komponent a speciálních průmyslových IT systémů.

 Uhlířská 1064/3, 710 00 Ostrava, Česká republika

 obchod@autocont-ipc.cz

 +420 552 301 002

 www.autocont-ipc.cz



PRŮMYSLOVÉ POČÍTAČE

fanless embedded PC, do racku, ...



POČÍTAČE S DISPLEJEM

panelové PC, terminály, do vozidel, ...



AUTOMATIZACE A SBĚR DAT

převodníky, karty, moduly, switche, ...



PERIFERIE A KOMPONENTY

monitory, klávesnice, desky, skříně, ...



NOTEBOOKY A TABLETY

odolné, windows, android, IP65, ...



INFORMAČNÍ KIOSKY

interiérové, venkovní, ...



MEDICÍNSKÁ TECHNIKA

počítače, tablety, LCD, klávesnice, ...



SOFTWAREVÁ ŘEŠENÍ

pro výrobu, zaměstnance, kiosky, ...



PŘEJÍT DO E-SHOPU

eshop.autocont-ipc.cz



DOPRAVA ZDARMA

Doprava zdarma v ČR a SR při objednávce nad 10 000 Kč bez DPH nebo nad 400 EUR.



PRODLOUŽENÁ ZÁRUKA

Záruka 2 roky na vyráběné počítače s možností jejího prodloužení až na 5 let.



ODMĚNA ZA VĚRNOST

Pravidelní zákazníci u nás nakupují za nižší ceny. Výše slevy se odvíjí od realizovaného obrátu.



SERVIS ON-SITE A IN-TIME

K projektovým dodávkám nabízíme rozšířenou podporu a servis s garancí výměny zařízení do 48 hodin.