

# S101M9

## 10.1" ARM A73 + A53 Rugged Tablet PC



### KEY FEATURES

- 10.1" 1920x 1200 TFT LCD Display
- 8.0 MP Camera in Front Side
- 13.0 MP Rear Camera (with LED auxiliary light, Auto Focus)
- 4 GB RAM + 32 GB eMMC
- Android™ 11.0
- Integrated 1D/2D Barcode Reader (Optional)
- Integrated NFC Module (Optional)



### SPECIFICATIONS

Display			
Resolution	1920x1200	Size	10.1 inches
Contrast Ratio	800:1	Panel Brightness	800 nits
View Angles	85,85,85,85	Bonding	Optical Bonding for Sunlight Viewability
Type	Projected Capacitive Multi Touch	Viewability	Anti-Glare touch treatment
Touch Mode	Support Hand / Gloves and Rain Mode		
System Specification			
Processor	ARM A73 x 4 (2.0 GHz) + A53 x 4 (2.0 GHz)	Memory	4GB
Storage	32GB	Operating System	Android 11.0
WLAN	Support	BT	Support
WWAN	4G/LTE (Optional)	GNSS	GPS/GLONASS
RFID	NFC (Read / Write, Peer to Peer mode) (Optional)	Sensors	Ambient Light Sensor, E-Compass, Gyro, Acceleration Sensors
Camera			
Front Camera	8MP Camera	Rear Camera	13MP Camera with LED Auxiliary Light (Auto Focus)
Mechanical			
Dimension	268 x 187 x 22.2 mm	Weight	1.0 kg
IO Ports			
USB Port	1 x USB Type C OTG 1 x USB Type A	SD Card Slot	1 x Micro SD Card Slot
SIM Card Slot	1 x SIM Card Slot	Video	1 x Micro HDMI (Optional)
Audio	1 x Audio Combo connector (Mic in or Line Out) 1 x Speaker	LAN	1 x RJ45 (Optional)
Indicator	2 x LED Indicators (Power, Battery)	Docking Connector	1 x Docking Connector
Environment			
Operating Humidity	10% to 90% RH, Non-Condensing	Operating Temperature	-10°C to 50°C (Battery mode)
Storage Temperature	-30°C to 70°C	Shock	MIL-STD-810H Method 516.6 Procedure I
Vibration	MIL-STD-810H Method 514.6 Procedure I	IP rating	IP65 Certified, Waterproof and Dustproof

<b>Drop</b>	MIL-STD-810H Method 516.6, 4 ft		
<b>Certification</b>			
<b>Certification</b>	CE, FCC		
<b>Control</b>			
<b>Button</b>	1 x Power Button, 2 x Function button		
<b>Power</b>			
<b>Battery</b>	11.4V, typ. 3500 mAh Li-Ion Battery, Support Warm Swap function (Optional)	<b>Battery Operating Time</b>	8Hr
<b>Power Rating</b>	19V	<b>Adapter</b>	19V 3.42A Adapter
<b>Security Function</b>			
<b>SOTI MobiControl</b>	SOTI MobiControl Compliance	<b>Kensington Lock</b>	Kensington Lock
<b>Barcode Scanner</b>			
<b>Barcode Scanner</b>	1D/2D Barcode Reader (Optional)		

## DIMENSIONS UNIT:MM

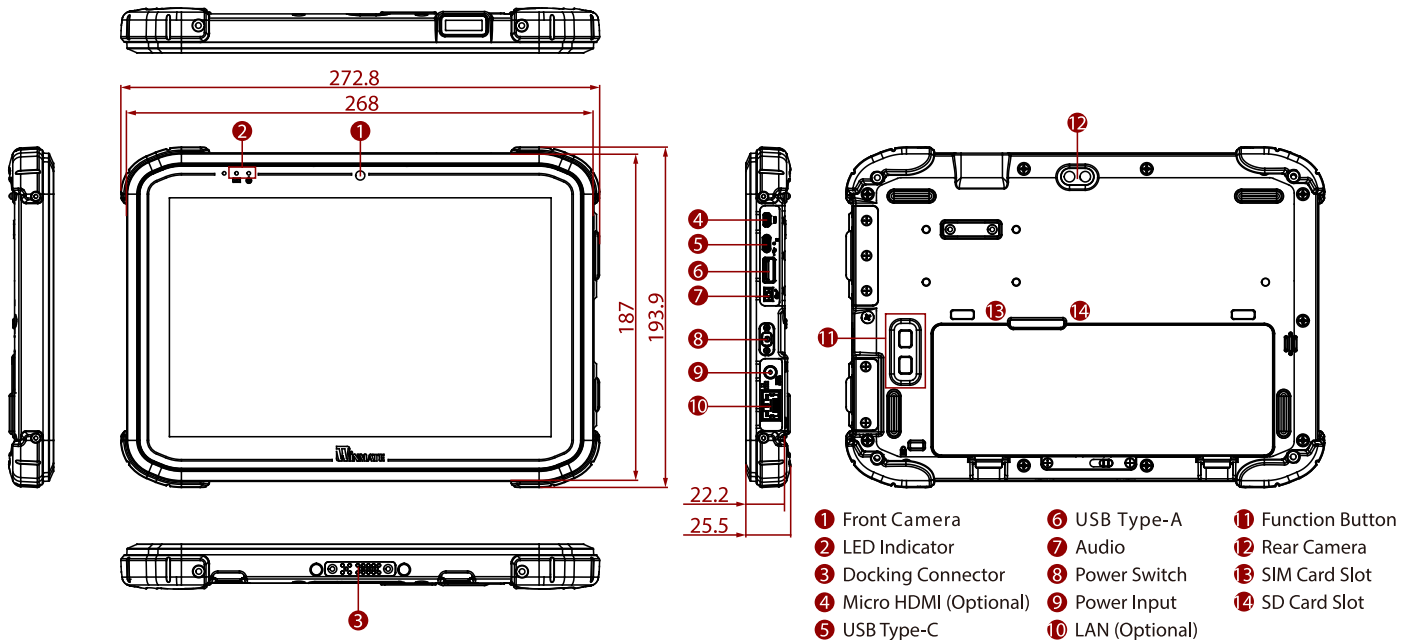

## NOTE

1. This is a simplified drawing and some components are not marked in detail.
2. Please contact our sales representative if you need further product information.
3. All specifications are subject to change without prior notice.
4. The product shown in this datasheet is a standard model. For diagrams that contain customized or optional I/O, please contact the Winmate Sales Team for more information.

# Tento produkt můžete zakoupit u společnosti AutoCont IPC a.s.



## AutoCont IPC a.s.

Váš dodavatel průmyslových počítačů, komponent a speciálních průmyslových IT systémů.

 Uhlířská 1064/3, 710 00 Ostrava, Česká republika

 [obchod@autocont-ipc.cz](mailto:obchod@autocont-ipc.cz)

 +420 552 301 002

 [www.autocont-ipc.cz](http://www.autocont-ipc.cz)



### PRŮMYSLOVÉ POČÍTAČE

*fanless embedded PC, do racku, ...*



### POČÍTAČE S DISPLEJEM

*panelové PC, terminály, do vozidel, ...*



### AUTOMATIZACE A SBĚR DAT

*převodníky, karty, moduly, switche, ...*



### PERIFERIE A KOMPONENTY

*monitory, klávesnice, desky, skříně, ...*



### NOTEBOOKY A TABLETY

*odolné, windows, android, IP65, ...*



### INFORMAČNÍ KIOSKY

*interiérové, venkovní, ...*



### MEDICÍNSKÁ TECHNIKA

*počítače, tablety, LCD, klávesnice, ...*



### SOFTWAREVÁ ŘEŠENÍ

*pro výrobu, zaměstnance, kiosky, ...*



### PŘEJÍT DO E-SHOPU

[eshop.autocont-ipc.cz](http://eshop.autocont-ipc.cz)



### DOPRAVA ZDARMA

Doprava zdarma v ČR a SR při objednávce nad 10 000 Kč bez DPH nebo nad 400 EUR.



### PRODLOUŽENÁ ZÁRUKA

Záruka 2 roky na vyráběné počítače s možností jejího prodloužení až na 5 let.



### ODMĚNA ZA VĚRNOST

Pravidelní zákazníci u nás nakupují za nižší ceny. Výše slevy se odvíjí od realizovaného obrátu.



### SERVIS ON-SITE A IN-TIME

K projektovým dodávkám nabízíme rozšířenou podporu a servis s garancí výměny zařízení do 48 hodin.