

## Features

- ▶ Industrial Fanless Panel PC
- ▶ Stainless steel 316L cased
- ▶ Display LCD TFT 21.5" Wide- LED backlight
- ▶ Resolution Full HD 1920 x 1080
- ▶ IP66 six sides
- ▶ CPU Intel® Atom™ Core Quad E3845
- ▶ Available with resistive touch screen
- ▶ Internal industrial power supply
- ▶ VESA 100 compatible
- ▶ Use your standard cables

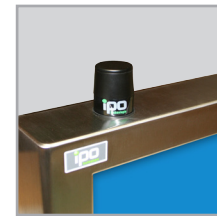

316L stainless steel  
IP66 six sides



Wifi internal with  
rugged antenna



IP66 I/O trap protection  
with cable gland

## I/O ports

- |                  |               |
|------------------|---------------|
| 1 - Power        | 10 - Micro    |
| 2 - USB 2.0      | 11 - Line in  |
| 3 - COM 2        | 12 - Line out |
| 4 - USB 2.0      |               |
| 5 - USB 3.0      |               |
| 6 - Ethernet 2   |               |
| 7 - Ethernet 1   |               |
| 8 - Display port |               |
| 9 - COM 1        |               |

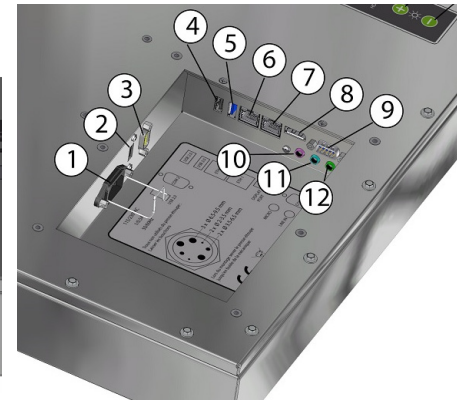

## Mechanical Drawing

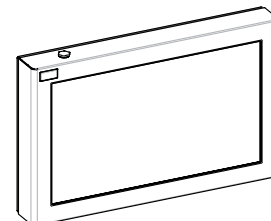
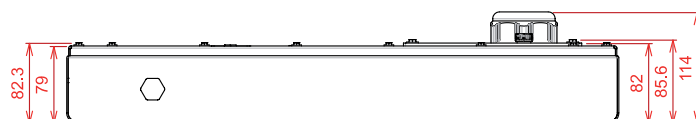
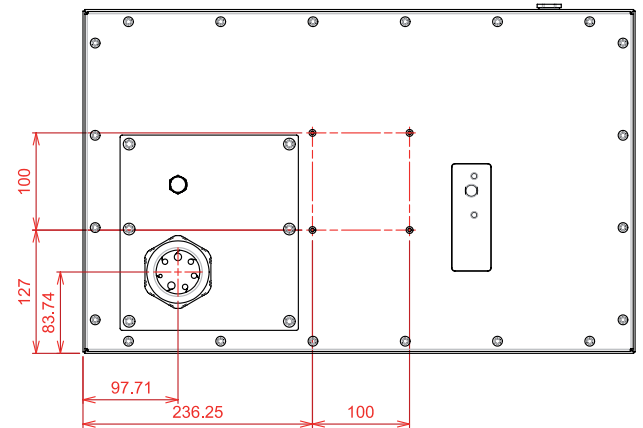
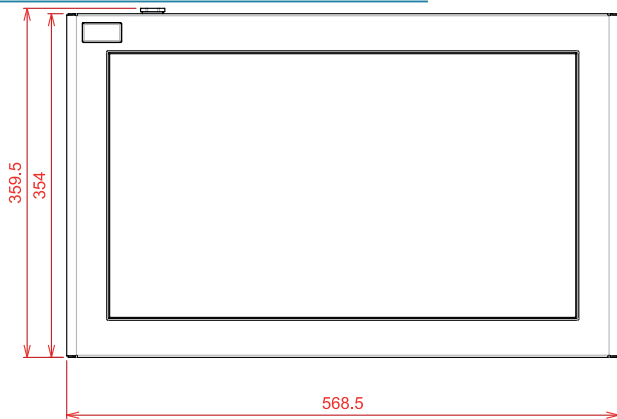

## Specifications

<b>Chassis</b>	Construction	1.5 mm thick - 316L stainless steel with treatment S4
	Version without touch screen	Tempered and anti-reflection Glass
	Mounting solution	VESA 100 compatible Stainless steel mounting solution: Table stand - wallmount - ...
<b>Display</b>	Protection	IP66 six sides
	LCD Size	21.5" Wide - LED Backlight
	Active area	476 x 268 mm
	Resolution	1920 x 1080 Full HD
	LCD Color	16.2 millions
	Pixel Pitch	0.294 mm
	Brightness	300 cd/m2
	Contrast Ratio	5000 : 1
<b>Touch Screen</b>	Angle maximum de vision	Horizontal : 170° - Vertical : 170°
	Technology	Resistive type (5-wire)
<b>CPU</b>	Processor	Intel® Atom™ Core Quad E3845 1.91 GHz
	Chipset	Intel® Atom™ SoC
	RAM	2x DDR3L SO-DIMM (max. 8.0 Go)
<b>Operating System</b>		Windows 7 / 8.1 / 10 - Linux on specification
<b>Drive bay</b>	HDD / SSD	1x 2"1/2 SATA
<b>I/O port under cover</b>		1x USB 3.0 - 2 x USB 2.0 - 2 x RS-232 - 1 x Display port
		2 x Gigabit Ethernet (RJ45) - 1 x Audio
<b>Cable gland</b>	Multicable (with standard cable)	Passage: 2 x Ø 6.5 - 8 mm - 1 for power cord
		Passage: 4 x Ø 3.5 - 6.5 mm
		Passage: 1 x Ø 2 - 3.5 mm
<b>Button &amp; Indicator</b>	Rear panel	ATX On/Off switch button
		Power Led - HDD activity Led
		Brightness control keypad
<b>System Cooling</b>		Fanless
<b>Dimensions</b>	Dimension WxHxD (mm)	568.5 x 359.5 x 114
	Weight (kg)	11.5
<b>Industrial Power Supply</b>	VAC~	Input: 115/230VAC - Frequency: 50/60Hz Power consumption: 50 W max.
<b>Safety &amp; EMC</b>	Security	EN60950-1
	EMC	EN55022, EN61000-3-2, EN61000-3-3, EN55024, EN-61000-4-2, EN-61000-4-3, EN-61000-4-4, EN-61000-4-5, EN-61000-4-6, EN-61000-4-8, EN-61000-4-11
<b>Environment</b>	Operating Temperature	0° ~ + 40°C
	Température de stockage	- 20 .... + 60°C
	Humidité sans condensation	5 ..... 95 %
<b>Warranty</b>		2 years Parts & Labour return to base as standard
<b>Options &amp; Accessories</b>	RT (in end of items)	Resistive Touch screen
	OPT/WIFI/ODY18W21W	Internal Wifi solution - mPCIe 802.11 a/b/g/n - 1xRugged antenna - 2.4GHz only
	OPT/BTH/USB/NMO/ODY	Internal bluetooth solution
	X/SUPPORTMUR/VIK	Wallmount support in 316L stainless steel
	OPT/PIEDTABLE/INOX	VESA 75/100 stand table support in 316L stainless steel



Stand mount support in 316L stainless steel



Wallmount support in 316L stainless steel



Head tube support in 316L stainless steel

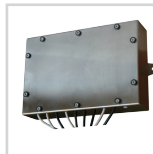

Plug box IP66 in 316L stainless steel



Protective cover for high pressure washing

## Ordering Information

**ODYSSEE21QA/AC** Industrial fanless Panel PC in stainless steel 316L chassis - IP66 six sides - LCD 21.5" Wide - Intel® Atom™ CQ E3845 - 230VAC

**ODYSSEE21QART/AC** Industrial fanless Panel PC in stainless steel 316L chassis - IP66 six sides - LCD 21.5" Wide - Intel® Atom™ CQ E3845 - Resistive touch screen - 230VAC

Please ask for additional information about : [Options & Accessories](#).

## Packing list

- 1 Power cord CE22 1.80 m (AC~ version)
- 1 Utility CD includes: User's manual
- 1 Utility CD includes: Drivers
- 1 Software Licence (label format)
- 1 Production&Traceability datasheet

# Tento produkt můžete zakoupit u společnosti AutoCont IPC a.s.



## AutoCont IPC a.s.

Váš dodavatel průmyslových počítačů, komponent a speciálních průmyslových IT systémů.

 Uhlířská 1064/3, 710 00 Ostrava, Česká republika

 [obchod@autocont-ipc.cz](mailto:obchod@autocont-ipc.cz)

 +420 552 301 002

 [www.autocont-ipc.cz](http://www.autocont-ipc.cz)



### PRŮMYSLOVÉ POČÍTAČE

*fanless embedded PC, do racku, ...*



### POČÍTAČE S DISPLEJEM

*panelové PC, terminály, do vozidel, ...*



### AUTOMATIZACE A SBĚR DAT

*převodníky, karty, moduly, switche, ...*



### PERIFERIE A KOMPONENTY

*monitory, klávesnice, desky, skříně, ...*



### NOTEBOOKY A TABLETY

*odolné, windows, android, IP65, ...*



### INFORMAČNÍ KIOSKY

*interiérové, venkovní, ...*



### MEDICÍNSKÁ TECHNIKA

*počítače, tablety, LCD, klávesnice, ...*



### SOFTWAREVÁ ŘEŠENÍ

*pro výrobu, zaměstnance, kiosky, ...*



### PŘEJÍT DO E-SHOPU

[eshop.autocont-ipc.cz](http://eshop.autocont-ipc.cz)



### DOPRAVA ZDARMA

Doprava zdarma v ČR a SR při objednávce nad 10 000 Kč bez DPH nebo nad 400 EUR.



### PRODLOUŽENÁ ZÁRUKA

Záruka 2 roky na vyráběné počítače s možností jejího prodloužení až na 5 let.



### ODMĚNA ZA VĚRNOST

Pravidelní zákazníci u nás nakupují za nižší ceny. Výše slevy se odvíjí od realizovaného obrátu.



### SERVIS ON-SITE A IN-TIME

K projektovým dodávkám nabízíme rozšířenou podporu a servis s garancí výměny zařízení do 48 hodin.