

# EKI-6333AC-1GPO Series

## Industrial IEEE 802.11 a/b/g/n/ac Wi-Fi AP



### Features

- Supports 802.11ac MIMO 2x2
- Supports wave 2 MU-MIMO that improves performance and expands user capacities
- WLAN transmission rate up to 867 Mbps
- Supports secure access with WEP, 802.1x, WPA/WPA2-Personal, WPA/WPA2-Enterprise
- Provides Web-based configuration
- Supports dual bands 2.4/5GHz concurrent
- IP67-rated waterproof & dustproof housing that withstands harsh environments

### Introduction

The EKI-6333AC-1GPO is a feature-rich wireless AP providing reliable wireless connectivity for industrial environments. EKI-6333AC-1GPO improves the reliability of wireless connectivity, especially in applications requiring high reliability and throughput data transmission. To secure the wireless connection, EKI-6333AC-1GPO implements the latest encryption technologies, including WPA2/WPA/802.1x for powerful security authentication.

### Specifications

#### Ethernet Communications

- **Port Type** RJ45
- **No. of Ports** 1
- **Interface** 1 x 10/100/1000 Base-T

#### Wireless LAN Communications

- **Compatibility** 2.4GHz: IEEE 802.11 b/g/n  
5GHz: IEEE 802.11 a/n/ac
- **Speed** 2.4GHz: 300Mbps(Max), 5GHz: 867Mbps(Max)
- **Network Mode** Infrastructure
- **Free Space Range** Open space 100 m  
Wireless Security WEP, WPA/WPA2-Personal, WPA/WPA2-Enterprise

#### Software

- **Management** Telnet, FTP, SNMP, Web UI, SSH
- **Wireless** Radio on/off, WMM, Output Power Control, Beacon Interval, RTS/CTS threshold, DTIM Interval
- **Operation Modes** Access Point mode, Client, Repeater
- **Configuration** Web Browser
- **Protocol** ARP, ICMP, IPv4, IPv6, TCP, UDP, DHCP Client, DHCP Server, Auto IP, Telnet, DNS, SNMP, HTTP, DMZ, PPPoE, VPN Passthrough, Telnet Server, SSH Server, FTP Server, QoS

#### Accessory Content

- Poll & Wall mounting kit
- Screw set
- External antenna x4

#### Antenna

- Default with 4 x external 5 dBi Omni antenna

#### Data Rates

- **802.11b** 11M, 5.5M, 2M, 1Mbps
- **802.11a/g** 54M, 48M, 36M, 18M, 12M, 9M, 6Mbps
- **802.11n** HT20 MCS0-15 / HT40 MCS0-15
- **802.11ac** VHT80 MCS0-9

#### Mechanics

- **Enclosure** Plastic
- **Mounting** Wall, Pole
- **Dimensions (W x H x D)** 111.2 x 173.6x 30.29 mm (4.37" x 6.83" x 1.19")
- **Weight** 316g

#### General

- **LED Indicators** System: Power  
WLAN: Link/Active  
LAN: Link/Active

#### Power Requirements

- **Power Input** 802.3af/at Compliance Source
- **Power Connector** PoE Adapter
- **Power Connector** RJ45
- **Power Consumption** 12.6W

#### Environment

- **IP Rating** IP67
- **Operating Temperature** -20 ~ 60 °C (-4~140°F)
- **Storage Temperature** -40°C to 80°C ( -40°F to 176°F)
- **Operating Humidity** 10 ~ 90% RH

## EKI-6333AC-1GPO Series

### Dimensions

Unit: mm [inch]

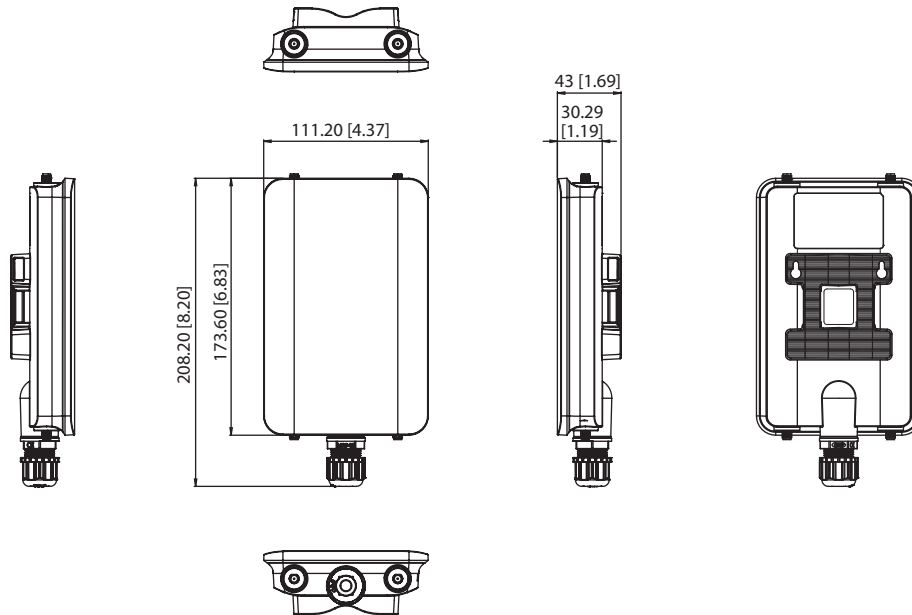

**Outline Dimension: 111.2 x 173.6 x 30.29 mm [4.37" x 6.83" x 1.19"]**

### Wireless Transmission Rates

- **Transmitted Power\***
  - 802.11a: 23 dBm@6Mbps
  - 802.11b: 23 dBm
  - 802.11g: 23 dBm@6Mbps
  - 802.11n HT20(2.4GHz): 23 dBm@ MCS 0/8
  - 802.11n HT40(2.4GHz): 23 dBm@ MCS 0/8
  - 802.11n HT20(5GHz): 23 dBm@ MCS 0/8
  - 802.11n HT40(5GHz): 23 dBm@ MCS 0/8
  - 802.11ac VHT80: 23 dBm @ MC 0
- **Receiver Sensitivity**
  - 802.11a: -89 dBm@6Mbps, -71 dBm@54Mbps
  - 802.11b: -92 dBm@1Mbps, -84 dBm@11Mbps
  - 802.11g: -89 dBm@6Mbps, -72 dBm@54Mbps
  - 802.11n HT20(2.4GHz): -87 dBm@MCS 0/8, -67 dBm@MCS 7/15
  - 802.11n HT40(2.4GHz): -84 dBm@MCS 0/8, -66 dBm@MCS 7/15
  - 802.11n HT20(5GHz): -89 dBm@MCS 0/8, -68 dBm@MCS 7/15
  - 802.11n HT40(5GHz): -86 dBm@MCS 0/8, -66 dBm@MCS 7/15
  - 802.11ac VHT80 -83dBm @MCS0; -56 dBm @MCS9

\*Note: The listed value is the target power calibrated in the card. The actual power will vary depending on each country's regulation

### Ordering Information

- **EKI-6333AC-1GPO-JA** 802.11 a/b/g/n/ac Wireless AP/Client for Japan
- **EKI-6333AC-1GPO-CA** 802.11 a/b/g/n/ac Wireless AP/Client for China

# Tento produkt můžete zakoupit u společnosti AutoCont IPC a.s.



## AutoCont IPC a.s.

Váš dodavatel průmyslových počítačů, komponent a speciálních průmyslových IT systémů.

 Uhlířská 1064/3, 710 00 Ostrava, Česká republika

 [obchod@autocont-ipc.cz](mailto:obchod@autocont-ipc.cz)

 +420 552 301 002

 [www.autocont-ipc.cz](http://www.autocont-ipc.cz)



### PRŮMYSLOVÉ POČÍTAČE

*fanless embedded PC, do racku, ...*



### POČÍTAČE S DISPLEJEM

*panelové PC, terminály, do vozidel, ...*



### AUTOMATIZACE A SBĚR DAT

*převodníky, karty, moduly, switche, ...*



### PERIFERIE A KOMPONENTY

*monitory, klávesnice, desky, skříně, ...*



### NOTEBOOKY A TABLETY

*odolné, windows, android, IP65, ...*



### INFORMAČNÍ KIOSKY

*interiérové, venkovní, ...*



### MEDICÍNSKÁ TECHNIKA

*počítače, tablety, LCD, klávesnice, ...*



### SOFTWAREVÁ ŘEŠENÍ

*pro výrobu, zaměstnance, kiosky, ...*



### PŘEJÍT DO E-SHOPU

[eshop.autocont-ipc.cz](http://eshop.autocont-ipc.cz)



### DOPRAVA ZDARMA

Doprava zdarma v ČR a SR při objednávce nad 10 000 Kč bez DPH nebo nad 400 EUR.



### PRODLOUŽENÁ ZÁRUKA

Záruka 2 roky na vyráběné počítače s možností jejího prodloužení až na 5 let.



### ODMĚNA ZA VĚRNOST

Pravidelní zákazníci u nás nakupují za nižší ceny. Výše slevy se odvíjí od realizovaného obrátu.



### SERVIS ON-SITE A IN-TIME

K projektovým dodávkám nabízíme rozšířenou podporu a servis s garancí výměny zařízení do 48 hodin.