

ECU-150

NXP i.MX8M Quad Core Cortex A53 High-Performance IoT Gateway with 2 x LAN, 2 x COM, 1 x USB

NEW



Features

- NXP i.MX8M Quad Core Cortex A53 1.3G CPU
- DDR4 2GB RAM, 16GB eMMC for system storage
- 2 x RS-232/485 isolated serial ports
- 2 x 10/100/1000 Ethernet ports
- 1 x Mini-PCIe for WIFI/Cellular/4G
- Support web service for remotely on-line monitoring
- Support SD card & on-line firmware update
- Support Modbus, IEC-60870-101/104 protocol
- Support Data logger on SD card
- Operation Temperature -40~70°C

Introduction

ECU-150 is an i.MX8M based high-performance IoT gateway, which has an open platform design with Quad Core processor, two RS-232/485 isolated serial ports, two 10/100/1000 Ethernet ports, one USB 3.0 port and operating temperature range of -40~70°C. It offers Mini-PCIe and M.2 slot for integrating Wi-Fi/4G/5G modules. With Linux operating system and EdgeLink configure tool, ECU-150 enable system integrators to develop applications precisely for solar power, electricity and factory, which require massive data collection, cloud based application and video related monitoring solutions.

Specifications

General

- **Certification** CE, FCC
- **Mounting** Wall-Mount/ DIN-Rail
- **Power consumption** 8W @ 24V_{DC}
- **Power Requirements** 10 ~ 30 V_{DC}

System

- **CPU** NXP i.MX8M Quad Core Cortex A53 1.3G
- **Memory** LPDDR4 2GB
- **Indicators** LEDs for Power, LAN (LINK, ACT), Serial (Tx, Rx), Programmable
- **Storage** 16GB eMMC for OS
- **SD Slot** 1 x Micro-SD slot
- **Display** 1 x HDMI resolution 1280 x 720 (Optional)
- **Watchdog** Yes
- **SIM Slot** 1 x Nano SIM slot
- **RTC** Yes
- **Security** TPM2.0 (Optional)
- **FRAM** 128KB (Optional)

Communication

- **Serial Port** 2 x RS-232/485, 50 ~ 115200 bps
- **Isolation** 2500 V_{DC}
- **Ethernet Port** 2 x 10/100/1000 RJ-45 ports
- **USB Port** 1 x USB3.0
- **Expansion** Interface: 1x Mini-PCIe (Full-size)
Type: WIFI/Cellular/4G
Signal: USB 2.0/PCIe (Optional)

Software

- **OS Support** Yocto Kernel 4.14/Ubuntu 20.04
- **Protocol Support*** DNP3.0 Client & Server,
OPC-UA Client & Server,
BACNet/IP Client & Server,
Modbus RTU/TCP Master & Slave,
IEC-60870-5-101 Master,
IEC-60870-5-103 Master,
IEC-60870-5-104 Master & Slave

- **PLC driver support** Siemens/Mitsubishi/Omron/Allen-Bradley, Delta etc
200+ PLC drivers
- **Programming Support** IEC-61131-3, Linux C, Python
- **Configuration Tool** WISE-EdgeLink Studio
- **Data Monitoring** 20000 Tags Max.

Environment

- **Operating Temperature** -40~70°C
- **Storage Temperature** -40~85°C
- **Humidity** 5~95% (non-condensing)

Ordering Information

- **ECU-150-12A** i.MX8M Quad Core Industrial Communication Gateway with 2 x LAN, 2 x COM, 1 x USB
- **ECU-150P-M1A** 2nd stack expansion module support 1 x M.2
- **ECU-150P-P2A** 2nd stack expansion module support 2 x mPCIe
- **ECU-150P-D1A** 2nd stack expansion module support 1 x iDOOR

Wi-Fi Solution

- **EWM-W172H01E** 802.11ac/a/b/g/n 2T2R Wi-fi + Bluetooth 4.2 Half
- **1750008717-01** WiFi 2.4GHz+5GHz dipole antenna
- **1750006043** Wi-Fi Coaxial Cable, 150 mm
- **9656EWMG00E** Half-size miniPCIe to miniPCIe bracket set

Cellular Solution (SIM card is not included)

- **96PD-EC25EFA** LTE Cat 4 Module with GNSS
- **1750006264** SMA(F) Cable, 15 cm
- **1750008303-01** Antenna AN0727-64SP6BSM
- **96PD-MDG200AU0** AMIC 4G.Cat4 Socket Modem(US)
- **1750006264** SMA(F) Cable, 15 cm
- **1750008303-01** Antenna AN0727-64SP6BSM

*Please refer to EdgeLink Protocol & Driver Support List for details

Dimensions

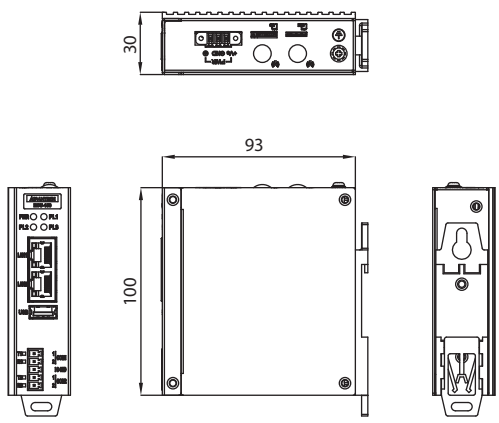

Front View

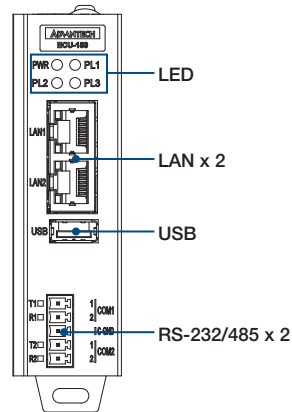

Top View

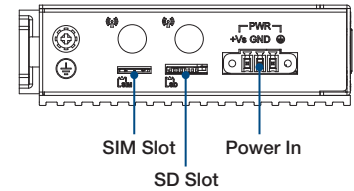

Dimensions with 2nd Stack

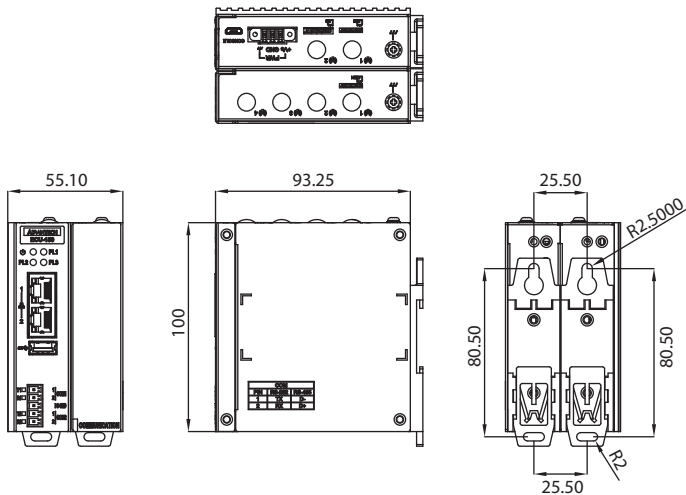

5G Module Supported

Manufacturer	Model
Quectel	RM500Q-GL
Quectel	RM502Q-AE (North America)
Unicom	CU-QM1
Fibocom	FM-150-AE
Gosuncn	GM800

iDoor Module Supported

- **PCM-24D2R2-BE** Isolated RS-232, DB9 x 2, (USB type)
- **PCM-24D2R4-BE** Isolated RS-422/485, DB9 x 2, (USB type)
- **PCM-24D4R4-BE** Non-Isolated RS-422/485, DB37 x 1 (USB Type)
- **PCM-26D2CA-AE** SJA1000 CANBus, CANOpen, DB9 x 2

Tento produkt můžete zakoupit u společnosti AutoCont IPC a.s.



AutoCont IPC a.s.

Váš dodavatel průmyslových počítačů, komponent a speciálních průmyslových IT systémů.

 Uhlířská 1064/3, 710 00 Ostrava, Česká republika

 obchod@autocont-ipc.cz

 +420 552 301 002

 www.autocont-ipc.cz



PRŮMYSLOVÉ POČÍTAČE

fanless embedded PC, do racku, ...



POČÍTAČE S DISPLEJEM

panelové PC, terminály, do vozidel, ...



AUTOMATIZACE A SBĚR DAT

převodníky, karty, moduly, switche, ...



PERIFERIE A KOMPONENTY

monitory, klávesnice, desky, skříně, ...



NOTEBOOKY A TABLETY

odolné, windows, android, IP65, ...



INFORMAČNÍ KIOSKY

interiérové, venkovní, ...



MEDICÍNSKÁ TECHNIKA

počítače, tablety, LCD, klávesnice, ...



SOFTWAREVÁ ŘEŠENÍ

pro výrobu, zaměstnance, kiosky, ...



PŘEJÍT DO E-SHOPU

eshop.autocont-ipc.cz



DOPRAVA ZDARMA

Doprava zdarma v ČR a SR při objednávce nad 10 000 Kč bez DPH nebo nad 400 EUR.



PRODLOUŽENÁ ZÁRUKA

Záruka 2 roky na vyráběné počítače s možností jejího prodloužení až na 5 let.



ODMĚNA ZA VĚRNOST

Pravidelní zákazníci u nás nakupují za nižší ceny. Výše slevy se odvíjí od realizovaného obrátu.



SERVIS ON-SITE A IN-TIME

K projektovým dodávkám nabízíme rozšířenou podporu a servis s garancí výměny zařízení do 48 hodin.