

TPC-71W

7" Touch Panel Computer with ARM Cortex™-A9 Processor

NEW



Features

- NXP® ARM® Cortex™-A9 i.MX6 dual/quad-core processor
- 7" 16:9 LCD with multi-touch P-CAP and true-flat IP66-rated front panel
- Up to 2 GB DDR3L RAM and 8 GB eMMC storage onboard
- 10/100/1000 Mbps LAN with optional IEEE 802.3at PoE-PD module support
- 1 mb FRAM backup memory for unexpected power interruptions
- Serial port with 120Ω termination resistor that supports the CAN 2.0B protocol and offers a programmable bit rate of up to 1 Mb/sec
- Embedded browser and VNC tool for rapid Web App development
- Supports Linux Yocto, Linux Ubuntu, Android and WEC7
- Optional NFC and mPCIe expansion modules
- Compatible with VESA and panel mounting
- Wide operating temperature range (-20 ~ 60 °C/-4 ~ 140 °F)

Introduction

TPC-71W is a compact touch panel computer equipped with an NXP® i.MX 6 Cortex™-A9 dual/quad-core processor, 7" TFT LCD display, multi-touch glass sensor, 2 GB of DDR3L RAM, and 8 GB of eMMC storage. To ensure stable operation in harsh industrial environments, TPC-71W supports a wide operating temperature range (-20 ~ 60 °C /-4 ~ 140 °F) and VESA mounting and features an IP66-rated front panel that protects against water and dust ingress.

For web-based operations, TPC-71W offers 10/100/1000 Mbps LAN that supports the IEEE 802.3 PoE-PD standard. The inclusion of VNC Tools and browsers enable rapid Web application development and easy configuration. Finally, TPC-71W supports various OS including Linux Yocto, Linux Ubuntu with full QT graphics, and Android to ensure easy deployment for diverse applications.

Specifications

General

- **Certification** CE, BSMI, CCC, UL, FCC Class A
- **Dimensions (W x H x D)** 205 x 146.92 x 46 mm (8.07 x 5.78 x 1.81 in)
- **Cutout Dimensions** 192 x 138.5 mm (7.56 x 5.45 in)
- **OS Support** Linux Yocto 2.1, Linux Ubuntu 16.04, Android 6 and Windows Embedded Compact 7
- **Power Input** 24V_{DC} ±20, 12V by project
- **Power Consumption** 9W (typical)
- **Unit Enclosure** Die-cast aluminum alloy front bezel
PC + ABS rear housing
- **Mount Options** Panel and VESA
- **Weight (Net)** 1.2 kg (2.65 lb)

System Kernel

- **CPU** NXP® ARM® Cortex™-A9 i.MX6 dual/quad-core
1.0 GHz processor
- **Backup Memory** FRAM 1 MB
- **Memory** Dual core: 1 GB DDR3L RAM
Quad core: 2 GB DDR3L RAM
- **Storage** 8 GB eMMC onboard

Communication Interface

- **Serial Port** 1 x DB9 selectable mode for RS-232/485 and CAN 2.0 B
- **LAN** 1 x RJ45 with 10/100/1000 Mbps
Optional module to support PoE PD
- **Others** 1 x USB 2.0 Type-B Client
2 x USB 2.0 Type-A Host
1 x Micro SD

LCD Panel

- **Panel Type** WSVGA TFT LCD
- **Panel Size** 7 in (177.8 mm)
- **Max. Resolution** 1024 x 600
- **Max. Colors** 16.7M
- **Luminance** 400 cd/m²
- **Viewing Angle (H/V)** 170/170
- **Backlight Life** 50,000 hrs
- **Treatment** Anti-glare
- **Contrast Ratio** 800:1
- **Front Panel LED Indicator** Yes

Touchscreen

- **Touch Points** 10 Points
- **Light** Transmission above 85%
- **Pencil Hardness** ≥7H
- **Type** Projected capacitive (P-CAP) touch

Environment

- **Operating Temperature** -20 ~ 60 °C (-4 ~ 140 °F)
- **Storage Temperature** -30 ~ 70 °C (-22 ~ 158 °F)
- **Humidity** 10 ~ 90% RH @ 40 °C, non-condensing
- **Ingress Protection** IP66-rated front panel
- **Vibration Protection** 2 Grms random vibration (5 ~ 500 Hz) during operation (compliant with IEC60068-2-64)
- **Shock Protection** 10 G shock under 11 ms operation (compliant with IEC60068-2-27)

Dimensions

Unit: mm

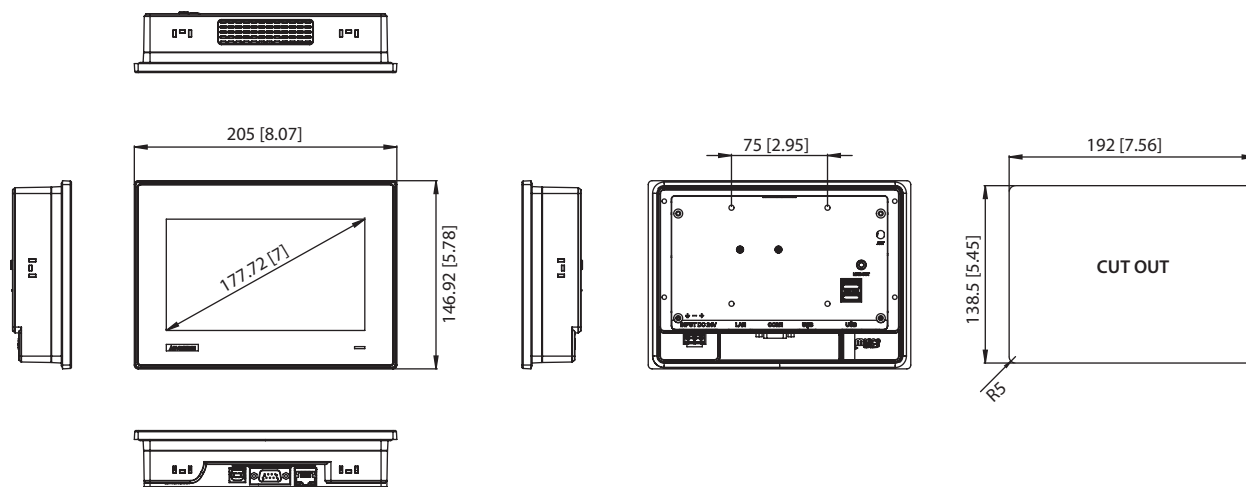

Panel Cutout Dimensions: 192 x 138.5 mm (7.56 x 5.45 in)

Ordering Information

- **TPC-71W-N10PA** 7" Touch Panel Computer, Cortex™-A9 Dual Core CPU, 1GB DDR3L, 8G eMMC, Ubuntu 16.04
- **TPC-71W-N21PA** 7" Touch Panel Computer, Cortex™-A9 Quad Core CPU, 2GB DDR3L, 8G eMMC, Ubuntu 16.04
- **TPC-71W-N21WA** 7" Touch Panel Computer, Cortex™-A9 Quad Core CPU, 2GB DDR3L, 8G eMMC, WEC7
- **TPC-71W-N21AA** 7" Touch Panel Computer, Cortex™-A9 Quad Core CPU, 2GB DDR3L, 8G eMMC, Android 6

Optional Accessories

- **98R3T71W000** PoE PD add-on module
- **96PSA-A60W24T2** Adaptor A/D 100 ~ 240V 60W 24V C14 cord-end terminal
- **1702002600** Power cable with US plug, 1.8 M
- **1702002605** Power cable with EU plug, 1.8 M
- **1702031801** Power cable with UK plug, 1.8 M
- **1702031836** Power cable with China/Australia plug, 1.8 M

PoE Module Expansion

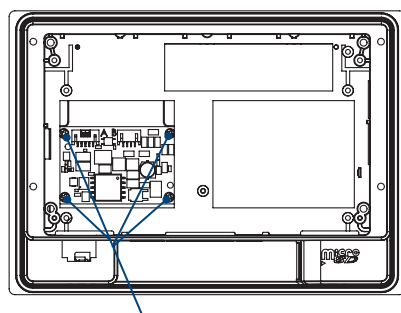

Screw M2.5x4L

External I/O

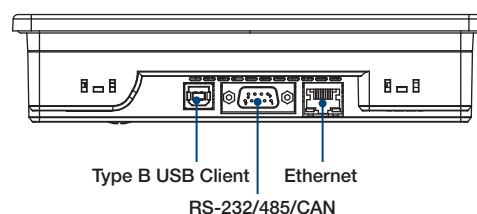
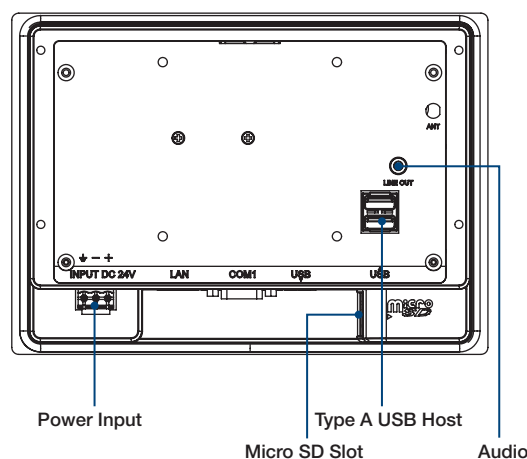

Please note: If some optional modules are offered with the system, additional system certificates may be required in certain regions/countries. Please contact Advantech for certificate compliance.

Tento produkt můžete zakoupit u společnosti AutoCont IPC a.s.



AutoCont IPC a.s.

Váš dodavatel průmyslových počítačů, komponent a speciálních průmyslových IT systémů.

 Uhlířská 1064/3, 710 00 Ostrava, Česká republika

 obchod@autocont-ipc.cz

 +420 552 301 002

 www.autocont-ipc.cz



PRŮMYSLOVÉ POČÍTAČE

fanless embedded PC, do racku, ...



POČÍTAČE S DISPLEJEM

panelové PC, terminály, do vozidel, ...



AUTOMATIZACE A SBĚR DAT

převodníky, karty, moduly, switche, ...



PERIFERIE A KOMPONENTY

monitory, klávesnice, desky, skříně, ...



NOTEBOOKY A TABLETY

odolné, windows, android, IP65, ...



INFORMAČNÍ KIOSKY

interiérové, venkovní, ...



MEDICÍNSKÁ TECHNIKA

počítače, tablety, LCD, klávesnice, ...



SOFTWAREVÁ ŘEŠENÍ

pro výrobu, zaměstnance, kiosky, ...



PŘEJÍT DO E-SHOPU

eshop.autocont-ipc.cz



DOPRAVA ZDARMA

Doprava zdarma v ČR a SR při objednávce nad 10 000 Kč bez DPH nebo nad 400 EUR.



PRODLOUŽENÁ ZÁRUKA

Záruka 2 roky na vyráběné počítače s možností jejího prodloužení až na 5 let.



ODMĚNA ZA VĚRNOST

Pravidelní zákazníci u nás nakupují za nižší ceny. Výše slevy se odvíjí od realizovaného obrátu.



SERVIS ON-SITE A IN-TIME

K projektovým dodávkám nabízíme rozšířenou podporu a servis s garancí výměny zařízení do 48 hodin.