

IPC-3012

Compact Chassis for PICMG 1.3 Half Size SHB



Features

- Compact chassis with two front expansion slots
- Shockproof drive bay for two 2.5" HDDs
- Equipped with 80 plus FLEX 250W power supply
- Thumb-screw for top cover easy opening
- Built-in Intrusion switch function
- Bidirectional to mount chassis on wall or workbench

CE FCC

Specifications

| | | | |
|--------------------------|---------------------------|--|--|
| Disk Drive Bay | 2.5" | External - | Internal 2 |
| Cooling | Fan Air Filters | 2 (6 cm/27 CFM) Yes | |
| Front I/O interface | USB | 2 | |
| Miscellaneous | LED Indicators Control | Power, HDD Power Switch | |
| System Monitoring | | Chassis intrusion switch | |
| Environment | Temperature | Operating 0 ~ 40 °C (32 ~ 104 °F) | Non-operating -20 ~ 60 °C (-4 ~ 140 °F) |
| | Humidity | 10 ~ 85 % @ 40 °C, non-condensing | 10 ~ 95 % @ 40 °C, non-condensing |
| | Vibration (5-500 Hz) | 1 Grms | 2 G |
| | Shock | 10 G (with 11 ms duration, half sine wave) | |
| Physical Characteristics | Dimensions (W x H x D) | 232 x 90 x 232 mm (9.13" x 3.54" x 9.13") | |
| | Weight | 3.24 kg (7.14 lb) | |

Front View

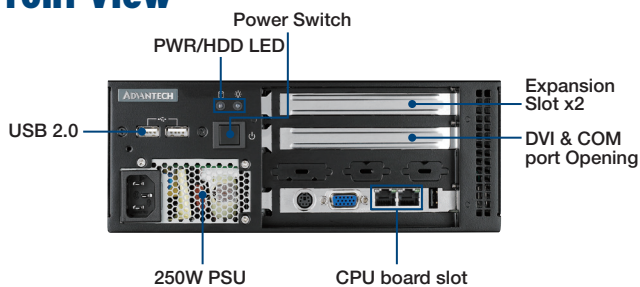

Rear View

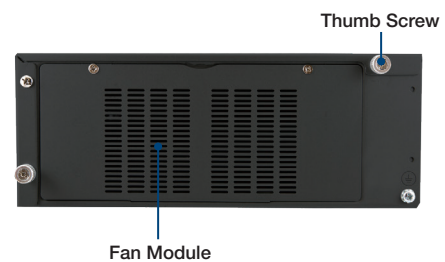

Inside View



Dimensions

Unit: mm [inch]

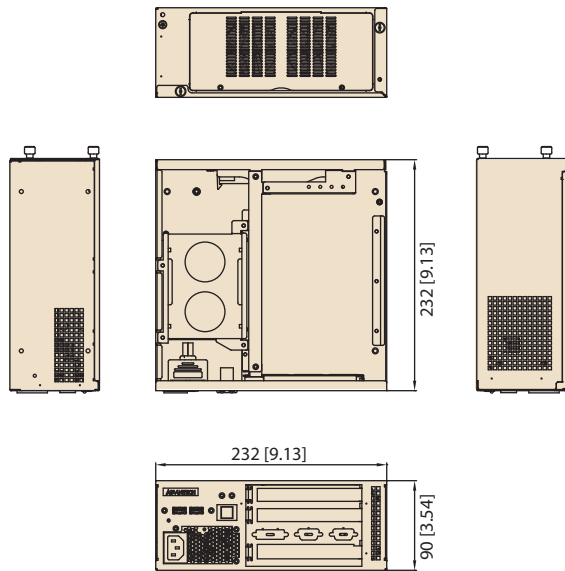

Installation

Unit: mm [inch]

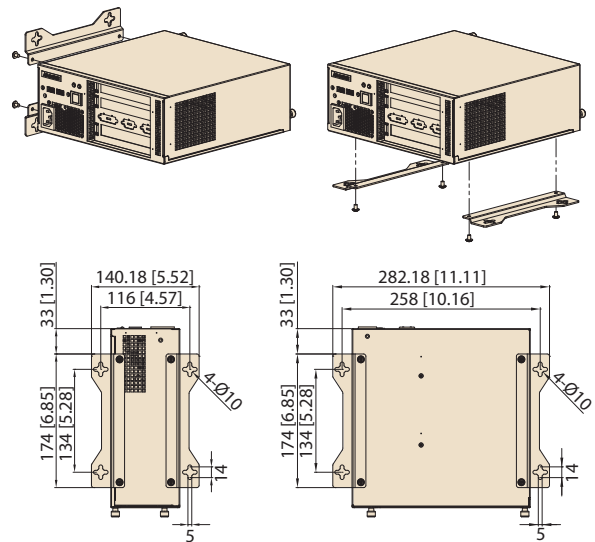

Ordering Information

| Part Number | Description |
|---------------|--|
| IPC-3012-25ZE | With 250W Power supply 96PS-A250WFX-2, with ATX switch |

Backplane Options

| Part Number | Description |
|-----------------|---|
| PCE-3B03A-00A1E | 3 Slots PICMG1.3BP, PCIe x16*1, PCIe x4*1 |
| PCE-3B03-01A1E | 3 Slots PICMG1.3BP, PCIe x16*1, 32-Bit/33 MHz PCI*1 |

Optional Accessories

| Part Number | Description |
|----------------|---|
| 1750006419 | 27.72 CFM, system fan 60 x 60 x 13 mm |
| 1990005760T00B | Filter cover |
| 1960053207N001 | 1.5U CPU cooler for one add-on card applied |
| 1960053065N001 | 1U CPU cooler for two add-on cards applied |

Tento produkt můžete zakoupit u společnosti AutoCont IPC a.s.



AutoCont IPC a.s.

Váš dodavatel průmyslových počítačů, komponent a speciálních průmyslových IT systémů.

 Uhlířská 1064/3, 710 00 Ostrava, Česká republika

 obchod@autocont-ipc.cz

 +420 552 301 002

 www.autocont-ipc.cz



PRŮMYSLOVÉ POČÍTAČE

fanless embedded PC, do racku, ...



POČÍTAČE S DISPLEJEM

panelové PC, terminály, do vozidel, ...



AUTOMATIZACE A SBĚR DAT

převodníky, karty, moduly, switche, ...



PERIFERIE A KOMPONENTY

monitory, klávesnice, desky, skříně, ...



NOTEBOOKY A TABLETY

odolné, windows, android, IP65, ...



INFORMAČNÍ KIOSKY

interiérové, venkovní, ...



MEDICÍNSKÁ TECHNIKA

počítače, tablety, LCD, klávesnice, ...



SOFTWAREVÁ ŘEŠENÍ

pro výrobu, zaměstnance, kiosky, ...



PŘEJÍT DO E-SHOPU

eshop.autocont-ipc.cz



DOPRAVA ZDARMA

Doprava zdarma v ČR a SR při objednávce nad 10 000 Kč bez DPH nebo nad 400 EUR.



PRODLOUŽENÁ ZÁRUKA

Záruka 2 roky na vyráběné počítače s možností jejího prodloužení až na 5 let.



ODMĚNA ZA VĚRNOST

Pravidelní zákazníci u nás nakupují za nižší ceny. Výše slevy se odvíjí od realizovaného obrátu.



SERVIS ON-SITE A IN-TIME

K projektovým dodávkám nabízíme rozšířenou podporu a servis s garancí výměny zařízení do 48 hodin.