

IPC-7132

Cost-effective Wallmount Chassis for ATX/uATX Motherboard



CE FCC

Features

- Supports ATX/uATX motherboard
- Shockproof drive bay for one 5.25" ODD and three 3.5" HDDs
- Thumb-screw for top cover easy opening
- Bidirectional option to mount chassis on wall or workbench
- Two front access USB ports

Specifications

		External	Internal
Disk Drive Bay	3.5"	1	2
	5.25"	1	-
Cooling	Fan	1 (12 cm/85 CFM)	
	Air Filters	Yes	
Front I/O interface	USB 2.0	2	
Miscellaneous	LED Indicators	Power, HDD	
	Control	Power Switch, System Reset Button	
	Rear panel	4x USB, 2x DB-9, 1x LPT port	
Environment	Temperature	Operating: 0 ~ 40 °C (32 ~ 104 °F)	Non-operating: -20 ~ 60 °C (-4 ~ 140 °F)
	Humidity	10 ~ 85 % @ 40 °C, non-condensing	10 ~ 95 % @ 40 °C, non-condensing
	Vibration (5-500 Hz)	1 Grms	2 G
	Shock	10 G (with 11 ms duration, half sine wave)	
	Dimensions (W x H x D)	200 x 330 x 430 mm (7.9" x 13" x 16.9")	
Physical Characteristics	Weight	9.96 kg (21.93 lb)	

Front View

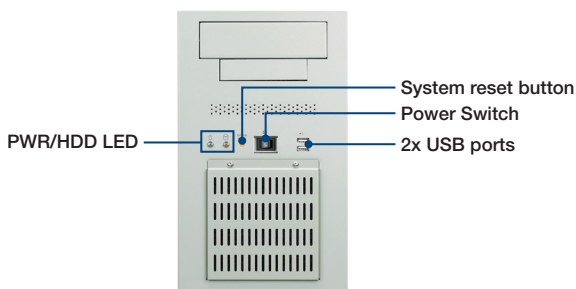

Rear View

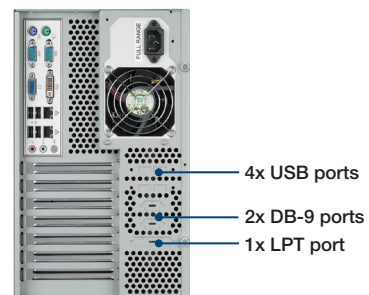

Inside View

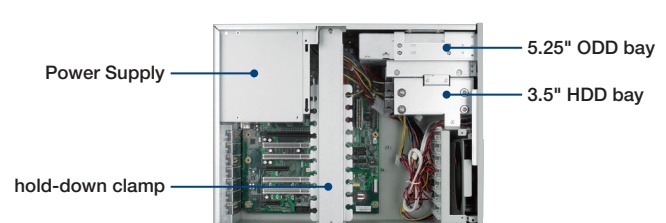

Easy-to-maintain cooling fan

Dimensions

Unit: mm [inch]

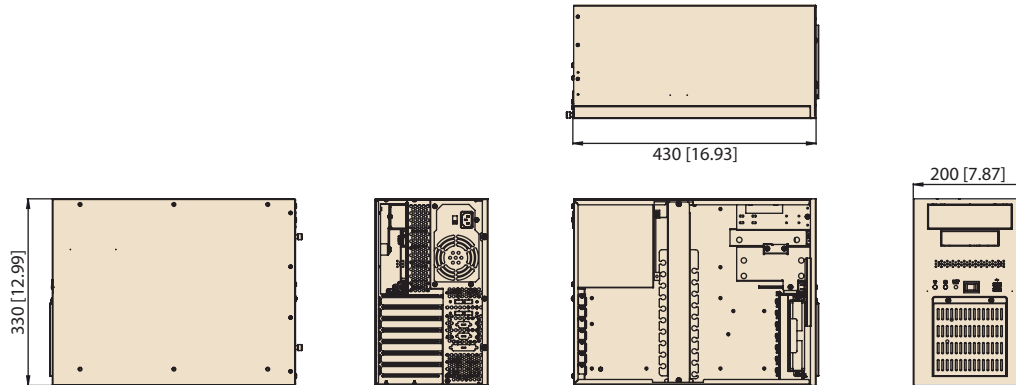

Installation

Unit: mm [inch]

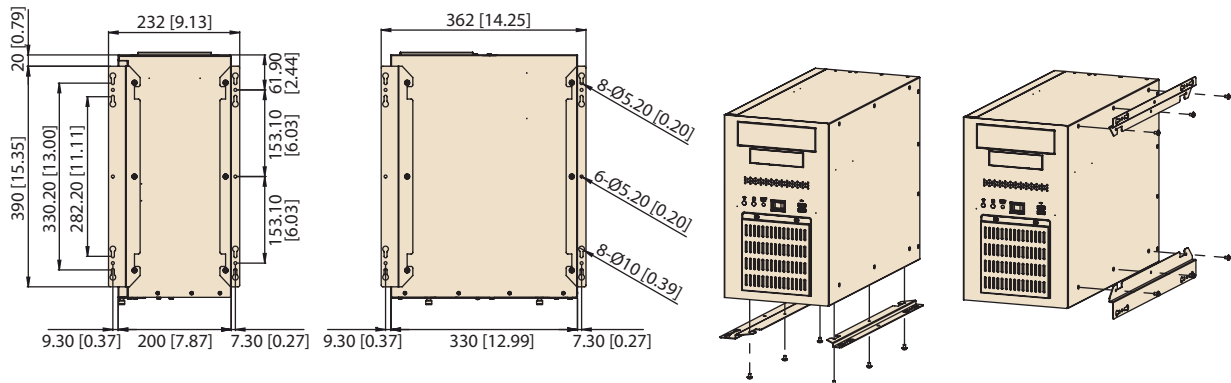

Ordering Information

Model Name	Power Supply	Wattage	Switch Type
IPC-7132MB-25ZE	PS8-250ATX-ZE	250W	ATX
IPC-7132MB-30ZE	PS8-300ATX-ZBE	300W	ATX
IPC-7132MB-40ZE	PS8-400ATX-ZE	400W	ATX

Optional Accessories

Part Number	Description
IPC-DT-3120E	Mobile HDD tray for dual 2.5" SATA HDDs
1750006427	87.87 CFM, system fan 120 x 120 x 25.0 mm

Tento produkt můžete zakoupit u společnosti AutoCont IPC a.s.



AutoCont IPC a.s.

Váš dodavatel průmyslových počítačů, komponent a speciálních průmyslových IT systémů.

 Uhlířská 1064/3, 710 00 Ostrava, Česká republika

 obchod@autocont-ipc.cz

 +420 552 301 002

 www.autocont-ipc.cz



PRŮMYSLOVÉ POČÍTAČE

fanless embedded PC, do racku, ...



POČÍTAČE S DISPLEJEM

panelové PC, terminály, do vozidel, ...



AUTOMATIZACE A SBĚR DAT

převodníky, karty, moduly, switche, ...



PERIFERIE A KOMPONENTY

monitory, klávesnice, desky, skříně, ...



NOTEBOOKY A TABLETY

odolné, windows, android, IP65, ...



INFORMAČNÍ KIOSKY

interiérové, venkovní, ...



MEDICÍNSKÁ TECHNIKA

počítače, tablety, LCD, klávesnice, ...



SOFTWAREVÁ ŘEŠENÍ

pro výrobu, zaměstnance, kiosky, ...



PŘEJÍT DO E-SHOPU

eshop.autocont-ipc.cz



DOPRAVA ZDARMA

Doprava zdarma v ČR a SR při objednávce nad 10 000 Kč bez DPH nebo nad 400 EUR.



PRODLOUŽENÁ ZÁRUKA

Záruka 2 roky na vyráběné počítače s možností jejího prodloužení až na 5 let.



ODMĚNA ZA VĚRNOST

Pravidelní zákazníci u nás nakupují za nižší ceny. Výše slevy se odvíjí od realizovaného obrátu.



SERVIS ON-SITE A IN-TIME

K projektovým dodávkám nabízíme rozšířenou podporu a servis s garancí výměny zařízení do 48 hodin.