

# FPM-3151G

## 15" XGA Industrial Monitor with Resistive Touch Control, Direct VGA, DVI Ports, and Wide Operating Temperature



### Features

- 15" XGA TFT LED LCD with 50K backlight lifetime
- Robust anodized aluminum-coated front bezel and stainless steel rear cover
- Wide operating temperature range (-20 ~ 60 °C/-4 ~ 140 °F)
- Increased reliability with enhanced 5-wire resistive touch sensor
- Anti-glare screen with tempered glass and IP65-certified front panel
- Ground isolation protection for entire system
- Supports VGA/DVI input, dual touch interfaces, and two power inputs
- Front-lockable OSD keys with user-defined functions
- IP65-rated front panel
- Supports panel, VESA, wall, desktop, and stand mounting

### Introduction

The FPM-3151G is an extremely rugged and reliable 15" XGA industrial monitor aimed at diverse industrial applications. Equipped with a hard anodized-aluminum coating, stainless steel chassis, and wide operating temperature range (-20 ~ 60 °C/-4 ~ 140 °F), FPM-3151G can withstand operation in a wide range of harsh industrial environments. This monitor also features enhanced 5-wire resistive touch control and overall ground isolation protection to enhance the system's reliability. Additionally, the FPM-3151G is equipped with lockable OSD keys on the front panel that control two user-defined function settings.

### Specifications

#### General

- **OSD Controls** OSD control pad on front panel with lockable function  
Two user-defined contrast/brightness settings
- **Certification** CE, FCC Class A, BSMI, CCC, UL, Energy Star
- **Dimensions (W x H x D)** 422 x 310 x 70 mm (16.61 x 12.2 x 2.76 in)
- **Enclosure** Front panel: Aluminum with hard anodizing coating  
Rear cover: Stainless steel with ground isolation protection
- **Mount Options** Panel, wall, desktop, VESA arm
- **Power Input** Phoenix Jack: 24 V<sub>DC</sub> input  
DC Jack: 12 V<sub>DC</sub> input
- **Power Consumption** 12W +20%
- **Video Port** VGA & DVI-D Port
- **Weight (Net)** 7.73 kg (17.04 lbs)

#### LCD Display

- **Display Type** XGA TFT LCD
- **Backlight Type** LED
- **Display Size** 15"
- **Max. Resolution** 1024 x 768
- **Max. Color** 16.2M (RGB 8-bit)
- **Viewing Angle (H/V °)** 160/140
- **Luminance (cd/m<sup>2</sup>)** 350
- **Backlight Life** 50,000 hr
- **Contrast Ratio** 700:1

#### Touchscreen

- **Driver** Penmount 6000
- **Type** 5-wire resistive with enhanced ITO film
- **Interface** USB & RS-232 (Combo)
- **Lifespan** 36 million with a silicone rubber R8 finger, writing rate is by 250g at 2 times/s
- **Light Transmission** > 80%
- **OS Support** Windows XP,2000,Vista,7,8/8.1,10 , XP/7/8/10 Embedded,CE,Linux
- **Power Consumption** +5 V @ 100 mA
- **Touch Resolution** Linearity

#### Environment

- **Operating Temperature** -20 ~ 60 °C (-4 ~ 140 °F)
- **Storage Temperature** -30 ~ 80 °C (-22 ~ 176 °F)
- **Humidity (Storage)** 90% @ 50 °C non-condensing
- **IP Rating** Front panel is IP65 compliant
- **Shock** 11ms, 10G (Non Operating, Half Sine Wave)
- **Vibration** 5 ~ 500 Hz, 1 Grms (Operating, Random)

### Ordering Information

- **FPM-3151G-R3BE** 15" XGA Ind. Monitor w/ Wide Temp, Resistive TS

## Dimensions

Unit: mm [inch]

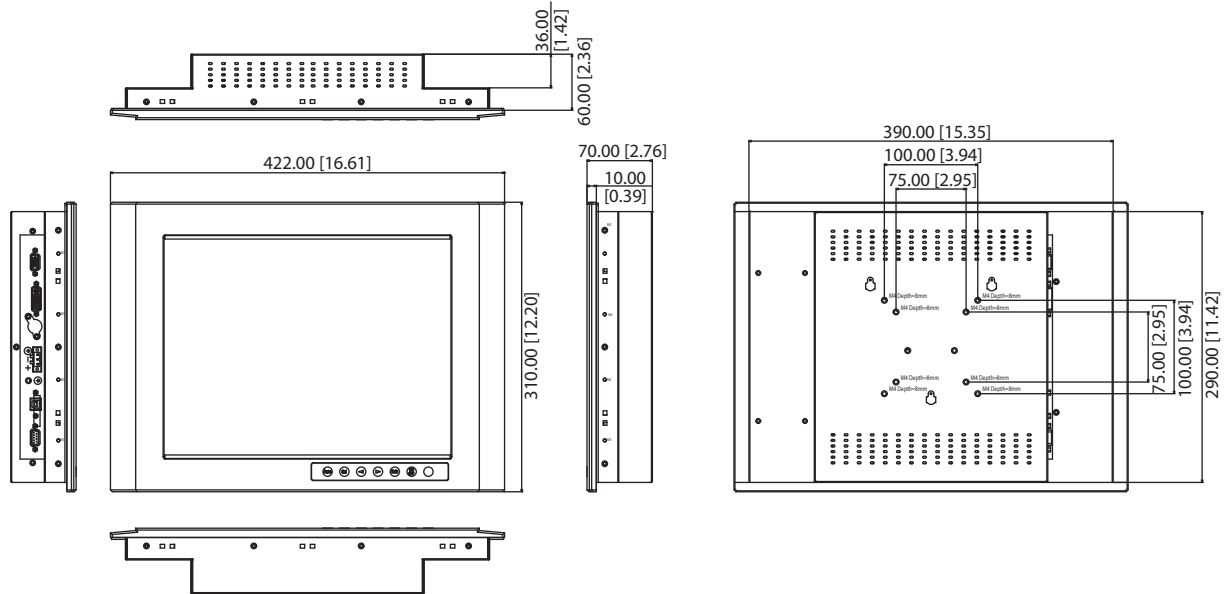

Panel Cutout Dimensions: 392 x 292 mm (15.43 x 11.49 in)

## Optional Accessories

- 1702002600 Power Cable US Plug 1.8 M
- 1702002605 Power Cable EU Plug 1.8 M
- 1702031801 Power Cable UK Plug 1.8 M
- 1700000596-11 Power Cable China/Australia Plug 1.8 M
- FPM-1000T-SMKE Desktop/Wall Mounting kit for FPM series
- 96PSA-A60W12V1-1 Adapter 100-240V 60W 12V 5A
- 96PSA-A60W24T2 Adapter 100-240V 60W 24V 2.5A
- FPM-3001G-ADKE Adapter bracket for FPM-3000 15"/17"/19"

## Rackmount (FPM-3151G-RMKE)



## I/O View

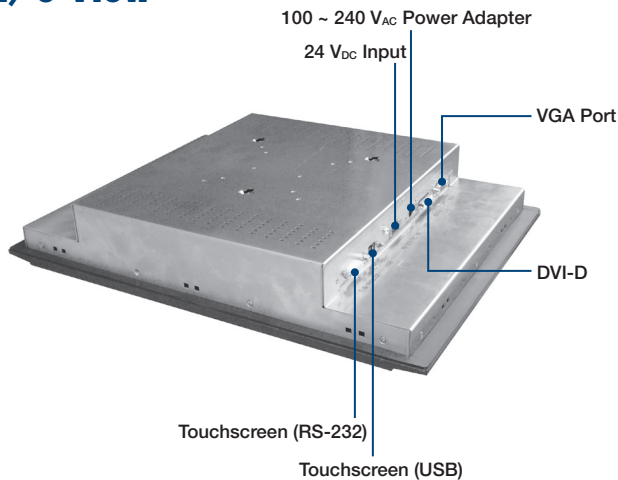

# Tento produkt můžete zakoupit u společnosti AutoCont IPC a.s.



## AutoCont IPC a.s.

Váš dodavatel průmyslových počítačů, komponent a speciálních průmyslových IT systémů.

 Uhlířská 1064/3, 710 00 Ostrava, Česká republika

 [obchod@autocont-ipc.cz](mailto:obchod@autocont-ipc.cz)

 +420 552 301 002

 [www.autocont-ipc.cz](http://www.autocont-ipc.cz)



### PRŮMYSLOVÉ POČÍTAČE

*fanless embedded PC, do racku, ...*



### POČÍTAČE S DISPLEJEM

*panelové PC, terminály, do vozidel, ...*



### AUTOMATIZACE A SBĚR DAT

*převodníky, karty, moduly, switche, ...*



### PERIFERIE A KOMPONENTY

*monitory, klávesnice, desky, skříně, ...*



### NOTEBOOKY A TABLETY

*odolné, windows, android, IP65, ...*



### INFORMAČNÍ KIOSKY

*interiérové, venkovní, ...*



### MEDICÍNSKÁ TECHNIKA

*počítače, tablety, LCD, klávesnice, ...*



### SOFTWAREVÁ ŘEŠENÍ

*pro výrobu, zaměstnance, kiosky, ...*



### PŘEJÍT DO E-SHOPU

[eshop.autocont-ipc.cz](http://eshop.autocont-ipc.cz)



### DOPRAVA ZDARMA

Doprava zdarma v ČR a SR při objednávce nad 10 000 Kč bez DPH nebo nad 400 EUR.



### PRODLOUŽENÁ ZÁRUKA

Záruka 2 roky na vyráběné počítače s možností jejího prodloužení až na 5 let.



### ODMĚNA ZA VĚRNOST

Pravidelní zákazníci u nás nakupují za nižší ceny. Výše slevy se odvíjí od realizovaného obrátu.



### SERVIS ON-SITE A IN-TIME

K projektovým dodávkám nabízíme rozšířenou podporu a servis s garancí výměny zařízení do 48 hodin.