

# TPC-1251T TPC-1551T TPC-1751T

## Thin-Client Terminal with Intel® Atom™ Processor



## Introduction

The TPC-xx51T thin-client terminal is the next-generation model of Advantech's TPC-xx51T industrial panel PC. Equipped with a TFT LCD, low-power Intel® Atom™ E3845, 1.91GHz, quad-core processor, and 4 GB of DDR3L SDRAM, TPC-xx51T delivers high-performance computing in a compact, fanless system. For enhanced durability to satisfy diverse industrial automation applications, TPC-xx51T supports a wide operating temperature range (-20 ~ 60 °C/-4 ~ 140 °F) and features a true-flat 5-wire resistive touchscreen with IP66-rated front panel, die-cast aluminum alloy front bezel, and 100 x 100 VESA mount kit. Moreover, with the provision of two full-size mini PCIe slots, which support mSATA interface for storage and USB/PCIe interface for Advantech's iDoor technology separately, TPC-xx51T can be easily expanded to provide additional I/O ports, isolated digital I/O, fieldbus protocols, MRAM, and 3G/GPS/GPRS/Wi-Fi communication capabilities.

## Specifications

### General

- **BIOS** AMI UEFI
- **Certification** BSMI, CCC, CE, FCC Class A, UL
- **Cooling System** Fanless design
- **Dimensions (W x H x D)**
  - 12.1": 311.8 x 238 x 55.4 mm (12.28 x 9.37 x 2.18 in)
  - 15": 383.2 x 307.3 x 55.9 mm (15.09 x 12.10 x 2.2 in)
  - 17": 410.4 x 343.4 x 56.9 mm (16.16 x 13.52 x 2.24 in)
- **Enclosure**
  - Front bezel: Die-cast aluminum alloy
  - Back housing: SECC
- **Mount Options** VESA mount, Desktop/wall/panel
- **OS Support** Microsoft® WES7 (32/64-bit), Windows 7 (32/64-bit), Windows 10 Enterprise LTSC, Android, Advantech Linux
- **Power Consumption**
  - 12.1": 25W Typical, 43.8W Max
  - 15": 25W Typical, 50W Max
  - 17": 29W Typical, 58W Max
- **Power Input** 24 V<sub>DC</sub> +/- 20%
- **Watchdog Timer** 1 ~ 255 sec (system)
- **Weight (Net)**
  - 12.1": 3.12 kg (6.88 lb)
  - 15": 4.4 kg (9.7 lb)
  - 17": 5.1 kg (11.24 lb)

### System Hardware

- **CPU** Intel® Atom™ E3845 1.91GHz Quad-core processor
- **Memory** 1 x SO-DIMM with 4 GB DDR3L SDRAM (up to 8 GB)
- **LAN** 2 x 10/100/1000 BASE-T
- **Expansion Slots** 1 x Full-size mini PCIe (USB+PCIe interface)
- **Storage** 1 x 2.5" SATA SSD, 1 x mSATA
- **I/O**
  - 1 x RS-232
  - 1 x RS-232/422/485
  - 1 x USB 3.0
  - 3 x USB 2.0
  - 1 x iDoor slot

### Touchscreen

- **Lifespan** 36 million touches at a single point
- **Light Transmission** Above 75%
- **Resolution** Linearity
- **Type** 5-wire analog resistive

## Features

- Intel® Atom™ E3845 1.91 GHz quad-core processor with 4 GB DDR3L SDRAM
- True-flat touchscreen with 5-wire resistive touch control and IP66-rated front panel
- Wide operating temperature range (-20 ~ 60 °C/-4 ~ 140 °F)
- Front-facing LED indicators to show operating status
- Advantech iDoor technology and SSD/HDD bay
- Compact, fanless system with aluminum alloy front bezel and chassis grounding protection
- Supports VESA mount (100 x 100 mm)
- Supports Advantech's SNMP Subagent software
- Supports Advantech's WISE-PaaS/RMM remote management software

### LCD

	TPC-1251T	TPC-1551T	TPC-1751T
<b>Display Type</b>	XGA TFT LED LCD	XGA TFT LED LCD	SXGA TFT LED LCD
<b>Display Size</b>	12"	15"	17"
<b>Max. Resolution</b>	1024 x 768	1024 x 768	1280 x 1024
<b>Max. Colors</b>	16.2M	16.2M	16.7M
<b>Luminance</b>	600 cd/m <sup>2</sup>	300 cd/m <sup>2</sup>	350 cd/m <sup>2</sup>
<b>Viewing Angle (H/V°)</b>	178/178	176/176	160/140
<b>Backlight Life</b>	50,000 hr	70,000 hr	50,000 hr
<b>Contrast Ratio</b>	1000:1	2000:1	800:1

### Environment

- **Humidity** 10 ~ 95% RH @ 40 °C, non-condensing
- **Ingress Protection** IP66-rated front panel
- **Operating Temperature** -20 ~ 60 °C (-4 ~ 140 °F)
- **Storage Temperature** -30 ~ 70 °C (-22 ~ 158 °F)
- **Vibration Protection** With SSD: 1 Grms (5 ~ 500 Hz) (operating, random vibration)

### Rear View

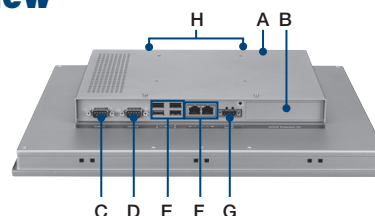

- A. HDD/SSD bay
- B. iDoor slot
- C. RS-232
- D. RS-232/422/485
- E. USB 2.0 and 3.0
- F. LAN (10/100/1000)
- G. Power input
- H. Antenna port

**Dimensions**

Unit: mm

**TPC-1251T**

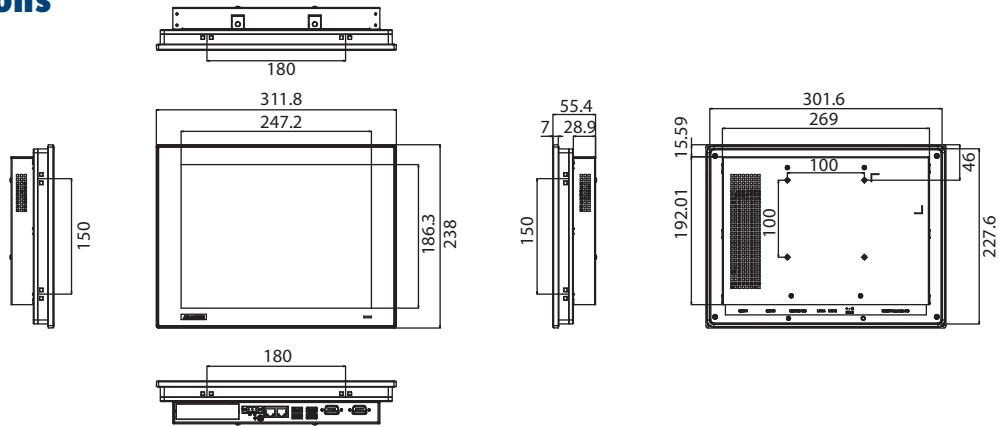

**Panel Cutout Dimensions: 303 x 229 mm (11.93 x 9.02 in)**

**TPC-1551T**

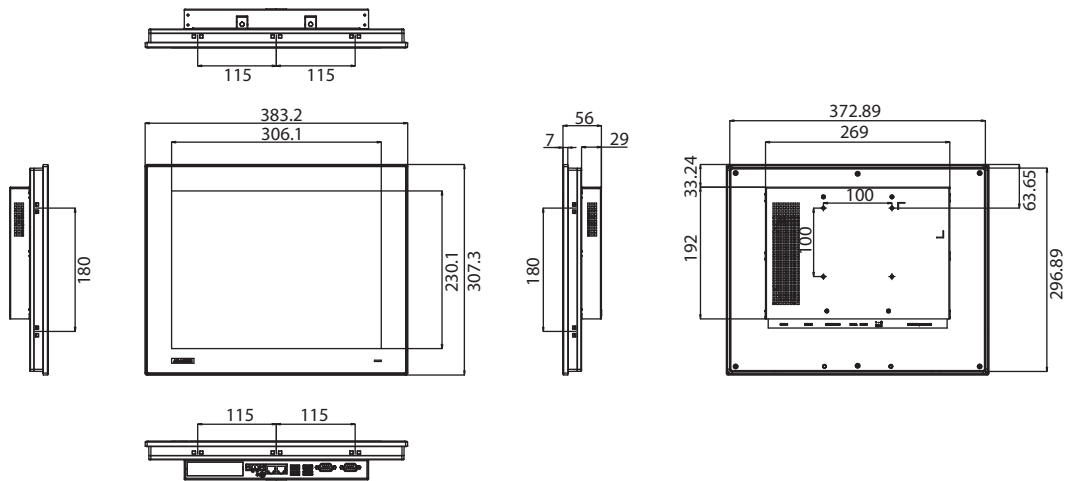

**Panel Cutout Dimensions: 374.5 x 298.5 mm (14.74 x 11.75 in)**

**TPC-1751T**

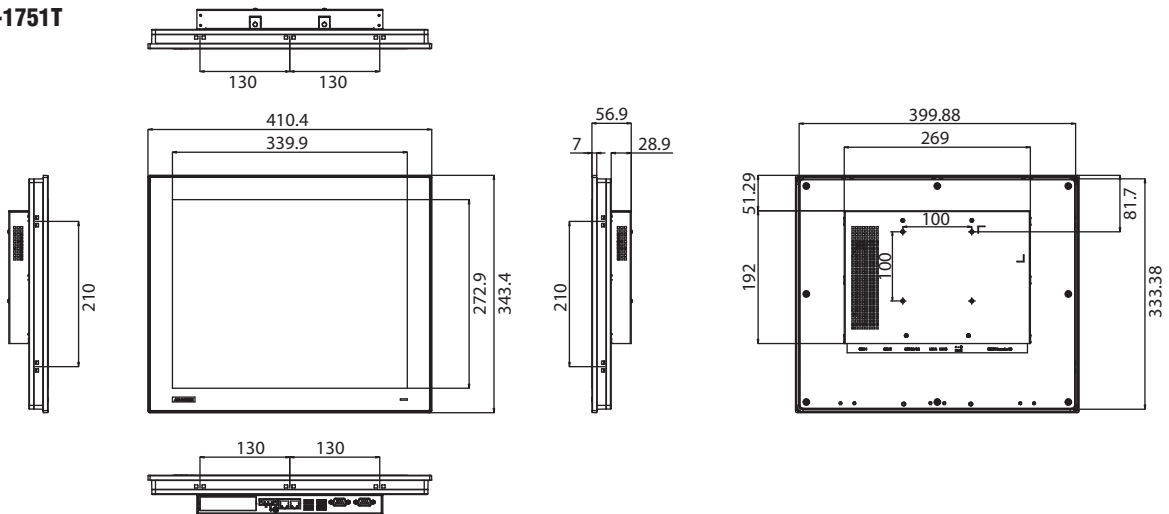

**Panel Cutout Dimensions: 401.3 x 334.8 mm (15.80 x 13.18 in)**

## Ordering Information

- **TPC-1251T-E3BE** 12.1" XGA Touch Panel PC, Atom E3845 1.91GHz, 4G
- **TPC-1251T-E3BU** 12.1" XGA Touch Panel PC, Atom E3845, 4G, for US
- **TPC-1251T-E3CE** 12.1" XGA Touch Panel PC, Atom E3845 1.91GHz, 4G
- **TPC-1251T-E3CU** 12.1" XGA Touch Panel PC, Atom E3845, 4G, for US
  
- **TPC-1551T-E3BE** 15" XGA Touch Panel PC, Atom E3845 1.91 GHz, 4G
- **TPC-1551T-E3BU** 15" XGA Touch Panel PC, Atom E3845, 4G, for US
- **TPC-1551T-E3CE** 15" XGA Touch Panel PC, Atom E3845 1.91 GHz, 4G
- **TPC-1551T-E3CU** 15" XGA Touch Panel PC, Atom E3845, 4G, for US
  
- **TPC-1751T-E3BE** 17" SXGA Touch Panel PC, Atom E3845 1.91 GHz, 4G
- **TPC-1751T-E3BU** 17" SXGA Touch Panel PC, Atom E3845, 4G, for US
- **TPC-1751T-E3CE** 17" SXGA Touch Panel PC, Atom E3845 1.91 GHz, 4G
- **TPC-1751T-E3CU** 17" SXGA Touch Panel PC, Atom E3845, 4G, for US

Note 1:

Can be equipped with an Intel® Celeron® J1900 CPU upon request

Note 2:

TPC-xx51T-xxBE version: Intel i210, 1GbE LAN chipset

TPC-xx51T-xxCE version: Realtek , RTL8119I-CG 1GbE LAN chipset

## Optional Accessories

- **PWR-247-DE** 60W 24 V<sub>DC</sub> /2.5A power supply
- **1702002600** Power cable (US) 1.8 M
- **1702002605** Power cable (EU) 1.8 M
- **1702031801** Power cable (UK) 1.8 M
- **1700000596-11** Power cable (China/Australia) 1.8 M
- **TPC-1000H-WMKE** TPC series wallmount kit from 10" -17"

## Embedded OS

- **20703WE7PS0027** TPC-xx51T(B) WS7P x86 MUI Image V4.19
- **20703WE7PS0028** TPC-xx51T(B) WS7P x64 MUI Image V4.19
- **20704WX1ES0005** Img WIN10 LTSC V6.08 B017 TPC-xx51(T)(WP) Entry
- **20703AIONS0010** TPC-xx51T(B) Android v6.0
- **20701LUB1S0005** TPC-xx51T(B) Advantech Linux Ubuntu 20.04

Note : Compatible with both B and C versions

## iDoor Modules

- **PCM-26D2CA-AE** SJA1000 CANbus module with CANopen and 2 x DB9
- **PCM-26D1DB-MAE** Hilscher netX100 fieldbus module with PROFIBUS and 1 x DB9
- **PCM-27D24DI-AE** Digital I/O module with 16 DI/8 DO, isolation protection, and 1 x DB37
- **PCM-24D2R4-BE** OXPcle-952 UART with isolated RS-422/485 and 2 x DB9
- **PCM-24D2R2-BE** OXPcle-952 UART with isolated RS-232 and 2 x DB9
- **PCM-24R2GL-AE** 2-Port GigaLAN Intel® i350 PCIe mini card
- **PCM-24R1TP-AE** Intel® 82574L, GbE, IEEE 1588 PTP, 1 x RJ45
- **PCM-26R2EC-MAE** Hilscher netX100 fieldbus mPCIe with EtherCAT, 2 x RJ45, Master
- **PCM-27J3AU-AE** 3-Port audio stereo with mPCIe and 3.5-mm jack
- **PCM-29R1TX-AE** 1-Port iLink(TX) long-distance display transmitter with RJ45

## Application Software

<b>WebAccess/SCADA</b>	Advantech WebAccess/SCADA is a 100% browser-based IIoT software platform aimed at supervisory control and data acquisition (SCADA) operations. WebAccess/SCADA provides open interfaces that allow our customers and partners to develop unique IoT applications for different vertical markets. In addition to supporting traditional SCADA functions, the platform features an HTML5-based user interface and intelligent dashboard to facilitate cross-platform, cross-browser data analysis. Moreover, WebAccess/SCADA not only offers built-in widgets, but is also equipped with an innovative Widget Builder that enables customers to build their own widgets.
<b>WebAccess/HMI</b>	Advantech WebAccess/HMI is human-machine interface (HMI) software based on Microsoft's Windows operating system. This software features excellent communication and monitoring capabilities, supports more than 350 PLC communication protocols, and offers a wide choice of screen design objects to satisfy diverse automation applications and HMI monitoring requirements.

Please note: If some optional modules are offered with the system, additional system certificates may be required in certain regions/countries. Please contact Advantech for certificate compliance.

# Tento produkt můžete zakoupit u společnosti AutoCont IPC a.s.



## AutoCont IPC a.s.

Váš dodavatel průmyslových počítačů, komponent a speciálních průmyslových IT systémů.

 Uhlířská 1064/3, 710 00 Ostrava, Česká republika

 obchod@autocont-ipc.cz

 +420 552 301 002

 [www.autocont-ipc.cz](http://www.autocont-ipc.cz)



### PRŮMYSLOVÉ POČÍTAČE

fanless embedded PC, do racku, ...



### POČÍTAČE S DISPLEJEM

panelové PC, terminály, do vozidel, ...



### AUTOMATIZACE A SBĚR DAT

převodníky, karty, moduly, switche, ...



### PERIFERIE A KOMPONENTY

monitory, klávesnice, desky, skříně, ...



### NOTEBOOKY A TABLETY

odolné, windows, android, IP65, ...



### INFORMAČNÍ KIOSKY

interiérové, venkovní, ...



### MEDICÍNSKÁ TECHNIKA

počítače, tablety, LCD, klávesnice, ...



### SOFTWAREVÁ ŘEŠENÍ

pro výrobu, zaměstnance, kiosky, ...



### PŘEJÍT DO E-SHOPU

[eshop.autocont-ipc.cz](http://eshop.autocont-ipc.cz)



### DOPRAVA ZDARMA

Doprava zdarma v ČR a SR při objednávce nad 10 000 Kč bez DPH nebo nad 400 EUR.



### PRODLOUŽENÁ ZÁRUKA

Záruka 2 roky na vyráběné počítače s možností jejího prodloužení až na 5 let.



### ODMĚNA ZA VĚRNOST

Pravidelní zákazníci u nás nakupují za nižší ceny. Výše slevy se odvíjí od realizovaného obrátu.



### SERVIS ON-SITE A IN-TIME

K projektovým dodávkám nabízíme rozšířenou podporu a servis s garancí výměny zařízení do 48 hodin.