

SFP-1FE Series

1-port fast Ethernet SFP modules



- > IEEE 802.3u compliant
- > Differential PECL inputs and outputs
- > TTL signal detect indicator
- > Hot pluggable LC duplex connector
- > Class 1 laser product; complies with EN 60825-1



Specifications

Interface

Ethernet Ports: 1
Connectors: Duplex LC Connector

Optical Fiber

	Fast Ethernet		
	SFP-M	SFP-S	SFP-L
Wavelength	1300 nm	1310 nm	1550 nm
Max. TX	-18 dBm	0 dBm	0 dBm
Min. TX	-8 dBm	-5 dBm	-5 dBm
RX Sensitivity	-34 dBm	-34 dBm	-34 dBm
Link Budget	26 dB	29 dB	29 dB
Typical Distance	4 km ^a	40 km ^b	80 km ^b
Saturation	0 dBm	-3 dBm	-3 dBm

a. 50/125 μm or 62.5/125 μm, 800 MHz * km @ 1300 nm multi-mode fiber optic cable
b. 9/125 μm single-mode fiber optic cable

Environmental Limits

Operating Temperature: -40 to 85°C (-40 to 185°F)
Storage Temperature: -40 to 85°C (-40 to 185°F)
Ambient Relative Humidity: 5 to 95% (non-condensing)

Standards and Certifications

Safety: UL 60950-1, TÜV

Warranty

Warranty Period: 5 years
Details: See www.moxa.com/warranty

Dimensions

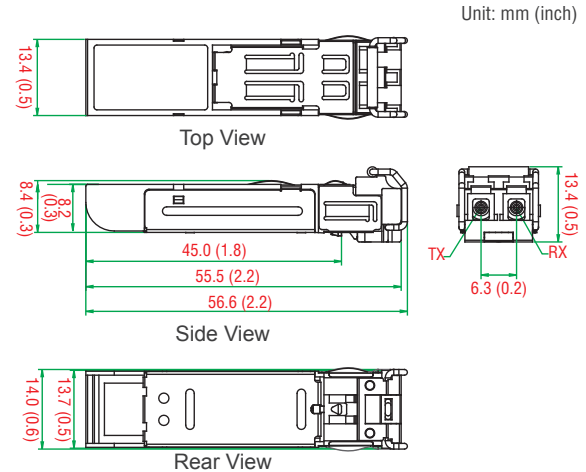

Ordering Information

Available Models	Port Interface			
	Wide Temperature (-40 to 85°C)	100BaseFX, Multi-mode, LC Connector, 4 km	100BaseFX, Single-mode, LC Connector, 40 km	100BaseFX, Single-mode, LC Connector, 80 km
SFP-1FEMLC-T		1	-	-
SFP-1FESLC-T		-	1	-
SFP-1FELLC-T		-	-	1

The SFP-1FE series modules can be used with the following products:

EDS-611/619 series, EDS-G509 series, EDS-G308-2SFP, EDS-P510 series, ICS-G7826/G7828 series, ICS-G7526/G7528 series, IM-G7000-4GSFP, IKS-G6824 series, IKS-G6524 series, IKS-6524-8SFP series, PM-7200-8SFP, EDR-G903 series

Package Checklist

- SFP-1FE module
- Warranty card

Tento produkt můžete zakoupit u společnosti AutoCont IPC a.s.



AutoCont IPC a.s.

Váš dodavatel průmyslových počítačů, komponent a speciálních průmyslových IT systémů.

 Uhlířská 1064/3, 710 00 Ostrava, Česká republika

 obchod@autocont-ipc.cz

 +420 552 301 002

 www.autocont-ipc.cz



PRŮMYSLOVÉ POČÍTAČE

fanless embedded PC, do racku, ...



POČÍTAČE S DISPLEJEM

panelové PC, terminály, do vozidel, ...



AUTOMATIZACE A SBĚR DAT

převodníky, karty, moduly, switche, ...



PERIFERIE A KOMPONENTY

monitory, klávesnice, desky, skříně, ...



NOTEBOOKY A TABLETY

odolné, windows, android, IP65, ...



INFORMAČNÍ KIOSKY

interiérové, venkovní, ...



MEDICÍNSKÁ TECHNIKA

počítače, tablety, LCD, klávesnice, ...



SOFTWAREVÁ ŘEŠENÍ

pro výrobu, zaměstnance, kiosky, ...



PŘEJÍT DO E-SHOPU

eshop.autocont-ipc.cz



DOPRAVA ZDARMA

Doprava zdarma v ČR a SR při objednávce nad 10 000 Kč bez DPH nebo nad 400 EUR.



PRODLOUŽENÁ ZÁRUKA

Záruka 2 roky na vyráběné počítače s možností jejího prodloužení až na 5 let.



ODMĚNA ZA VĚRNOST

Pravidelní zákazníci u nás nakupují za nižší ceny. Výše slevy se odvíjí od realizovaného obrátu.



SERVIS ON-SITE A IN-TIME

K projektovým dodávkám nabízíme rozšířenou podporu a servis s garancí výměny zařízení do 48 hodin.