



CAN Series Products



Intelligent CAN to Ethernet Gateway RoHS CE FC



I-7540D

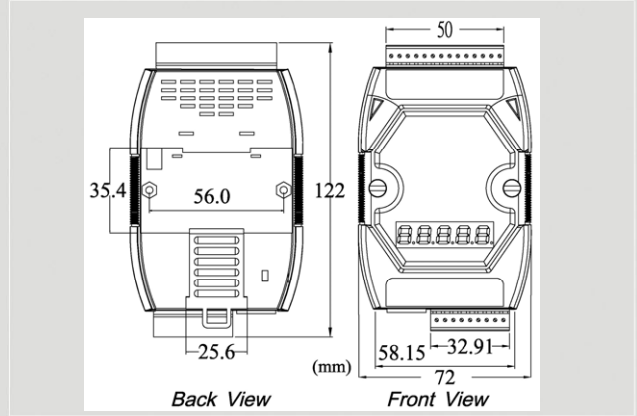

Dimensions

The I-7540D by ICP DAS is a solution that enables CAN networks to be integrated into the Internet/Ethernet, whereby remote monitor and control is possible. The I-7540D controls networked communication and makes a transparent CAN-based application interface available to the user. The device supports not only a transparent and protocol-independent transfer of the CAN messages, but virtual COM technology. Thus it allows to be implemented into a various applications.

Features

- 80186, 80 MHz CPU, or compatible
- 10/100 Base-TX Ethernet controller
- Message transmitted by using TCP/IP protocol
- COM driver support interrupt and 1K QUEUE input & output buffer
- Use one RS-232 port, one RS-485 port and one CAN port simultaneously
- 2500Vrms photo-isolation protection on CAN side.
- Jumper for 120Ω terminator resistor for CAN channel
- NXP 82C250 CAN Transceiver
- Support both CAN specification 2.0A and 2.0B.
- Max transmission speed up to 1M bps for CAN and 115.2kbps for RS-232 & RS-485
- Max transmission distance of CAN over 1000m (follow CAN specification)
- 7-segment LED display
- Software configuration for CAN and RS-232 communication parameters
- Firmware updated from COM 1 or Ethernet port
- Web Configuration
- Provide maximum 25 Ethernet client connections
- Support Virtual COM technology

Utility Features

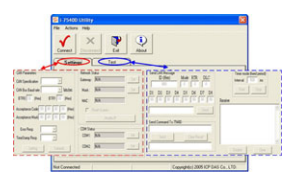

- IP、Gateway and Mask configuration
- CAN bus baud rate configuration
- CAN BTR0 and BTR1 configuration
- CAN acceptance filter configuration
- CAN 2.0A or 2.0B specific selection
- Error code response selection
- Utility tool for transmitting / receiving CAN messages

CAN Monitor & Data log Tools

- Show CAN messages by hex or decimal format
- CAN messages with timestamp
- Easy-to-use data logger for the diagnosis of the CAN networks and recording of the received data
- Send the predefined CAN messages manually or cyclically

Wire Assignments

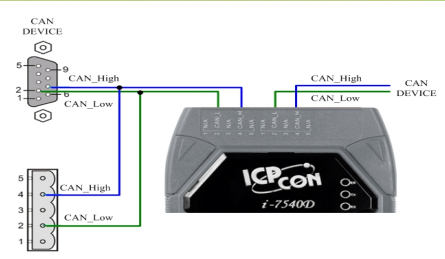

Hardware Specifications

CAN Interface	
Controller	NXP SJA1000T with 16 MHz clock
Transceiver	NXP 82C250
Channel number	1
Connector	2-pin screwed terminal block (CAN L, CAN H)
Baud Rate (bps)	10 k, 20 k, 50 k, 125 k, 250 k, 500 k, 800 k, 1 M (allow user-defined baud rate)
Isolation	1000 V _{DC} for DC-to-DC, 2500 V _{rms} for photo-couple
Terminator Resistor	Jumper for 120 Ω terminator resistor
Specification	ISO-11898-2, CAN 2.0A and CAN 2.0B
UART Interface	
COM 1	RS-232
COM 1 Connector	5-pin screwed terminal block (TxD, RxD, RTS, CTS, GND)
COM 2	RS-485 (Self-turner inside)
COM 2 Connector	2-pin screwed terminal block (DATA+, DATA-)
Baud Rate (bps)	110, 150, 300, 600, 1200, 2400, 4800, 9600, 19200, 38400, 57600, 115200
Data bit	7, 8
Stop bit	1
Parity	None, Even, Odd
Ethernet Interface	
Controller	10/100Base-TX Ethernet Controller (Auto-negotiating, Auto_MDIX)
Connector	RJ-45 with LED indicator
Power	
Power supply	Unregulated +10 ~ +30 V _{DC}
Protection	Power reverse polarity protection, Over-voltage brown-out protection
Power Consumption	2.5 W
Mechanism	
Installation	DIN-Rail
Dimensions	72mm x 122mm x 33mm (W x L x H)
Environment	
Operating Temp.	-25 ~ 75 °C
Storage Temp.	-30 ~ 80 °C
Humidity	10 ~ 90% RH, non-condensing

Applications

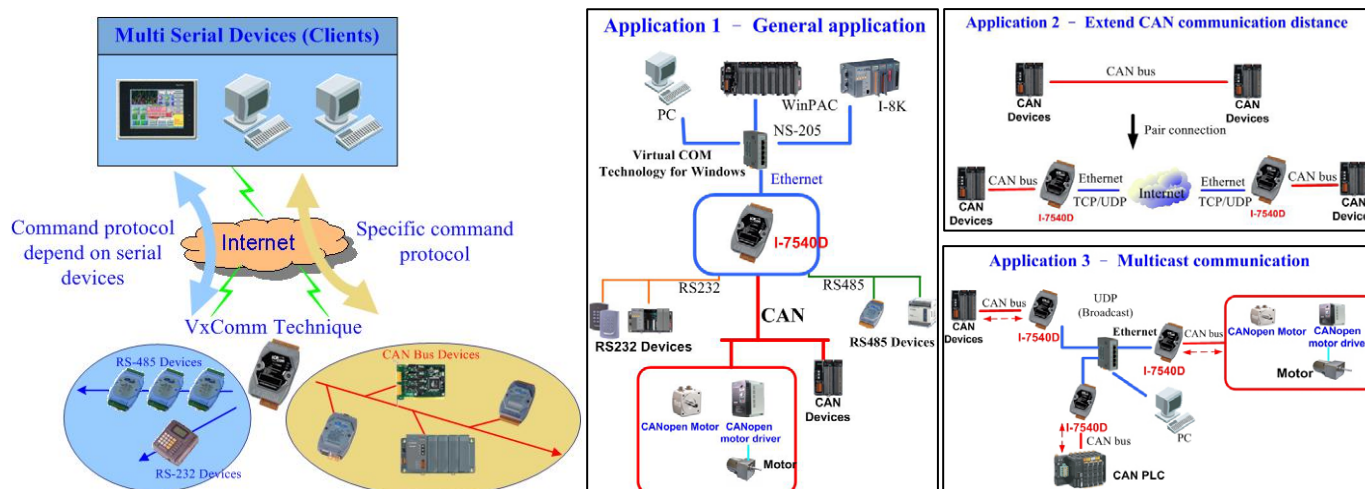

Ordering Information

I-7540D-G	Intelligent CAN to Ethernet Gateway
I-7540D-G CR	Intelligent CAN to Ethernet Gateway (RoHS)

Tento produkt můžete zakoupit u společnosti AutoCont IPC a.s.



AutoCont IPC a.s.

Váš dodavatel průmyslových počítačů, komponent a speciálních průmyslových IT systémů.

 Uhlířská 1064/3, 710 00 Ostrava, Česká republika

 obchod@autocont-ipc.cz

 +420 552 301 002

 www.autocont-ipc.cz



PRŮMYSLOVÉ POČÍTAČE

fanless embedded PC, do racku, ...



POČÍTAČE S DISPLEJEM

panelové PC, terminály, do vozidel, ...



AUTOMATIZACE A SBĚR DAT

převodníky, karty, moduly, switche, ...



PERIFERIE A KOMPONENTY

monitory, klávesnice, desky, skříně, ...



NOTEBOOKY A TABLETY

odolné, windows, android, IP65, ...



INFORMAČNÍ KIOSKY

interiérové, venkovní, ...



MEDICÍNSKÁ TECHNIKA

počítače, tablety, LCD, klávesnice, ...



SOFTWAREVÁ ŘEŠENÍ

pro výrobu, zaměstnance, kiosky, ...



PŘEJÍT DO E-SHOPU

eshop.autocont-ipc.cz



DOPRAVA ZDARMA

Doprava zdarma v ČR a SR při objednávce nad 10 000 Kč bez DPH nebo nad 400 EUR.



PRODLOUŽENÁ ZÁRUKA

Záruka 2 roky na vyráběné počítače s možností jejího prodloužení až na 5 let.



ODMĚNA ZA VĚRNOST

Pravidelní zákazníci u nás nakupují za nižší ceny. Výše slevy se odvíjí od realizovaného obrátu.



SERVIS ON-SITE A IN-TIME

K projektovým dodávkám nabízíme rozšířenou podporu a servis s garancí výměny zařízení do 48 hodin.