



Features

- Built-in Web Server
- Web HMI
- Support for MQTT Protocol
- 2-port Ethernet Switch for Daisy-Chain Topology
- Dual Watchdog
- Wide Operating Temperature Range: -25 ~ +75°C
- Built-in I/O
 - DI: 8 Channels
 - DO: 8 Channels



Introduction

The MQ-7244M is an Ethernet I/O device equipped with 8-channel DI and 8-channel DO, as well as the MQTT protocol is supported for connecting with a variety of digital sensors in Industrial Internet of Things (IIoT) applications. A web-based user interface is provided to configure module, monitor the network connection status and I/O status, and control digital output channels on the module via a normal web browser on a mobile device or computer.

The MQ-7244M features optical isolation for 2500 VDC of transient overvoltage protection, but doesn't provide channel-to-channel isolation. Each output channel can drive up to 650 mA load, together with configurable power-on value and safe value. It can safely be used in applications where hazardous voltages are present.

System Specifications

Model	MQ-7244M
Software	
Built-in Web Server	Yes
Web HMI	Yes
Communication	
Ethernet Port	2 x RJ-45, 10/100 Base-TX, Switch Ports
Protocol	MQTT 3.1.1
Dual Watchdog	Yes, Module (0.8 seconds), Communication (Configurable)
PoE	-
LED Indicators	
for System Running	Yes
for Ethernet Link/Act	Yes
for DI/DO status	Yes
2-Way Isolation	
Ethernet	1500 VDC
I/O	2500 VDC
EMS Protection	
ESD (IEC 61000-4-2)	±4 kV Contact for Each Terminal and ±8 kV Air for Random Point
EFT (IEC 61000-4-4)	±4 kV for Power Line
Surge (IEC 61000-4-5)	-
Power	
Reverse Polarity Protection	Yes
Powered from Terminal Block	+12 ~ +48 VDC
Consumption	3.3 W
Mechanical	
Dimensions (L x W x H)	120 mm x 97 mm x 42 mm
Housing	Metal
Installation	Wall Mounting
Environment	
Operating Temperature	-25 ~ +75°C
Storage Temperature	-30 ~ +80°C
Humidity	10 ~ 90% RH, Non-condensing

I/O Specifications

Model	MQ-7244M
Digital Input	
Channels	8
Contact	Wet
Sink/Source (NPN/PNP)	Sink/Source
ON Voltage Level	+10 VDC ~ +50 VDC
OFF Voltage Level	+4 VDC Max.
Input Impedance	10 kΩ
Overvoltage Protection	+70 VDC
Digital Output	
Channels	8
Type	Isolated Open Collector
Sink/Source (NPN/PNP)	Sink
Max. Load Current	650 mA/channel at 25°C Direct Drive Power Relay Module
Load Voltage	3.5 VDC ~ 50 VDC
Overvoltage Protection	60 VDC
Overload Protection	1.4 A
Short-circuit Protection	Yes
Power-on Value	Yes, Configurable
Safe Value	Yes, Configurable

Pin Assignments

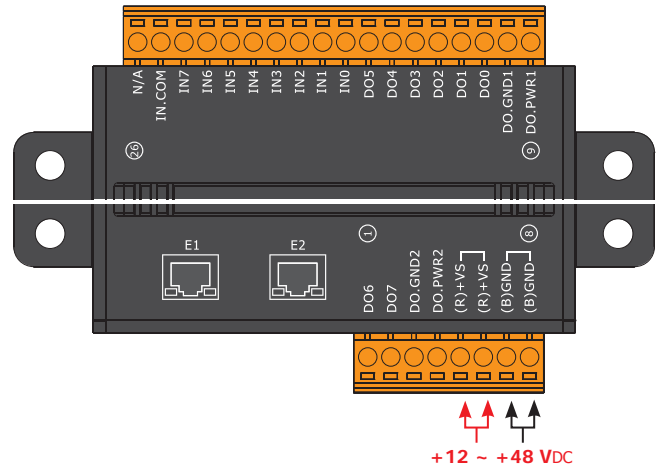

Dimensions (Units: mm)

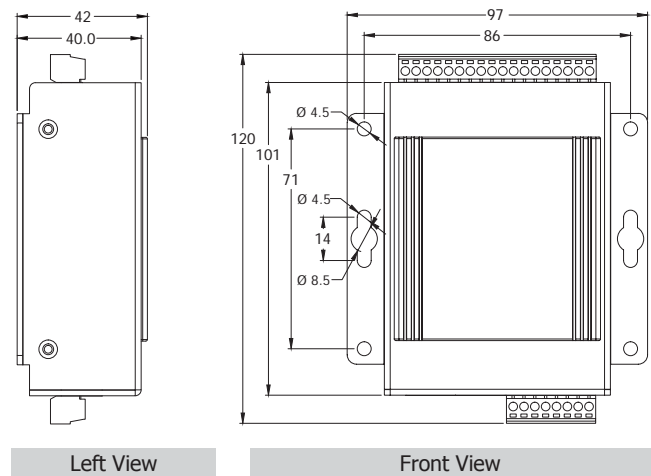

Wire Connections

Digital Input	Readback as 1	Readback as 0
Sink	+10 ~ +50 VDC 	OPEN or <4 VDC
	+10 ~ +50 VDC 	OPEN or <4 VDC

Output Type	ON State Readback as 1	OFF State Readback as 0
Drive Relay		
Resistance Load		

Ordering Information

MQ-7244M CR	MQTT I/O Module with 2-port Ethernet Switch, with 8-ch DI and 8-ch DO (RoHS)
-------------	--

Tento produkt můžete zakoupit u společnosti AutoCont IPC a.s.



AutoCont IPC a.s.

Váš dodavatel průmyslových počítačů, komponent a speciálních průmyslových IT systémů.

 Uhlířská 1064/3, 710 00 Ostrava, Česká republika

 obchod@autocont-ipc.cz

 +420 552 301 002

 www.autocont-ipc.cz



PRŮMYSLOVÉ POČÍTAČE

fanless embedded PC, do racku, ...



POČÍTAČE S DISPLEJEM

panelové PC, terminály, do vozidel, ...



AUTOMATIZACE A SBĚR DAT

převodníky, karty, moduly, switche, ...



PERIFERIE A KOMPONENTY

monitory, klávesnice, desky, skříně, ...



NOTEBOOKY A TABLETY

odolné, windows, android, IP65, ...



INFORMAČNÍ KIOSKY

interiérové, venkovní, ...



MEDICÍNSKÁ TECHNIKA

počítače, tablety, LCD, klávesnice, ...



SOFTWAREVÁ ŘEŠENÍ

pro výrobu, zaměstnance, kiosky, ...



PŘEJÍT DO E-SHOPU

eshop.autocont-ipc.cz



DOPRAVA ZDARMA

Doprava zdarma v ČR a SR při objednávce nad 10 000 Kč bez DPH nebo nad 400 EUR.



PRODLOUŽENÁ ZÁRUKA

Záruka 2 roky na vyráběné počítače s možností jejího prodloužení až na 5 let.



ODMĚNA ZA VĚRNOST

Pravidelní zákazníci u nás nakupují za nižší ceny. Výše slevy se odvíjí od realizovaného obrátu.



SERVIS ON-SITE A IN-TIME

K projektovým dodávkám nabízíme rozšířenou podporu a servis s garancí výměny zařízení do 48 hodin.